

# Wireless Internal Siren System Installation Guide



FW-VESTA -8/9F

FW-SIREN2CP -8/9F

P/N 7101958

REV-A

July 2010

## **Copyright©Crow Engineering Ltd. 2008**

The copyright of this document is owned by Crow Engineering Ltd., its agents and/or professional advisors. No part of parts hereof may be reproduced, distributed, republished, displayed, broadcast, hyperlinked or transmitted in any manner or by any means or stored in an information retrieval system without the prior written permission of Crow Engineering Ltd. or the copyright owner provided that permission is granted to download and print the materials in this document for personal, non-commercial use only provided you do not modify the materials and that you retain all copyright and other proprietary notices contained in the materials. This permission terminates automatically if you breach any of these terms or conditions. Upon termination, you will immediately destroy any downloaded and printed materials.

## **Trademarks**

The trade marks, service marks, and logos (the "Trade Marks") used and displayed in this document are registered and unregistered Trade Marks of Crow Engineering Ltd. and others. Nothing in this document should be construed as granting, by implication, estoppel, or otherwise, any license or right to use any Trade Mark displayed in this document, without the written permission of Crow Engineering Ltd. or other Trade Mark owners. The name of Crow Engineering Ltd. or the Crow Engineering Ltd. logo may not be used in any way, including in advertising or publicity pertaining to distribution of materials in this document, without prior written permission.

## **Disclaimer**

The information in this manual was accurate and reliable at the time of its release. However, we reserve the right to change the specifications of the product described in this manual without notice at any time.

# Contents

<b>INTRODUCTION</b> .....	<b>2</b>
<b>GENERAL DESCRIPTION</b> .....	<b>2</b>
<b>TRANSCIVER UNIT DESCRIPTION</b> .....	<b>2</b>
<b>SIREN UNIT DESCRIPTION</b> .....	<b>3</b>
<b>UNIT CONNECTION DIAGRAM</b> .....	<b>4</b>
<b>PHYSICAL LOCATIONS</b> .....	<b>5</b>
<b>TRANSCIVER UNIT</b> .....	<b>5</b>
<b>SIREN UNIT</b> .....	<b>6</b>
<b>LEARNING MODE</b> .....	<b>7</b>
<b>LEARNING THE TRANSCIVER IN THE C.P AS ZONE (BUS MODE)</b> .....	<b>7</b>
<b>LEARNING THE SIRENS (BUS AND STANDALONE)</b> .....	<b>8</b>
<b>FUNCTION TESTING AFTER LEARNING.</b> .....	<b>8</b>
<b>INSTALLATION INSTRUCTIONS</b> .....	<b>9</b>
<b>INSTALLING THE TRANSCIVER</b> .....	<b>9</b>
<b>INSTALLING THE SIREN UNITS</b> .....	<b>10</b>
<b>MAINTENANCE</b> 12	
<b>LOW BATTERY INDICATION</b> .....	<b>12</b>
<b>CHANGING THE SIREN BATTERY</b> .....	<b>12</b>
<b>ERASING THE SIREN MEMORY.</b> .....	<b>12</b>
<b>ERASING THE TRANSCIVER MEMORY.</b> .....	<b>12</b>
<b>SPECIFICATION: SIREN UNIT</b> .....	<b>13</b>
<b>SPECIFICATION: TRANSCIVER UNIT</b> .....	<b>14</b>

## General Description

The Wireless Siren System is composed of Transceiver Unit and Siren Alert devices. The Transceiver unit is connected to Alarm System Control Panel, and sends its commands to activate the Siren Unit(s) by Wireless communication Transceiver.

The Siren system can be operated at two modes, BUS mode or Standalone mode. The BUS mode is designed for working in front of the Runner and the Standalone mode is for any Control Panel.

The Transceiver can support up to 8 Sirens, the Sirens are synchronized and fully supervised by the Transceiver.

The Siren unit is powered by Lithium Battery 3.6V/14Ah .

## Transceiver Unit Description

- The Transceiver Unit has two modes of operation:
  - BUS mode, Connected to the Runner BUS and communicates to the Control Panel via this connection.
  - Standalone mode, connected to a control panel via terminal inputs and outputs. This connection allows interface to any type of Control Panel.
- One Transceiver can control up to 8 Siren Units. In BUS mode the sirens can be divided to two separate groups. (Separate siren activation to each group)  
Dipswitch to select between the two operation modes – See Table 1
- Two types of controls can be sent to each siren. One to activate/deactivate the siren, second to provide short beeps when arming and disarming the Alarm System.
- Two physical inputs (IN-1 & IN-2) are used for both modes – See Table 2
- The Transceiver includes an on-board Tamper switch for optional installation in separate housing.
- Tamper out Terminals for connection to Tamper Input of the Control Panel.
- Tamper Out Terminal is activate (open circuit)on the follow events:
  - Tamper open at the Siren Unit.
  - Transceiver on board tamper open.
- At BUS mode the transceiver can be learned as detector and the Control Panel will receive events as Tamper, Supervision and Low Battery.
- At BUS mode the Transceiver send Supervision over the BUS every 7 min while communication to Siren Unit is O.K.

## Siren Unit Description

- ✦ Powered by non rechargeable battery Lithium 3.6V/14Ah.
- ✦ Alarm signal will activate the Piezo Siren and the LED.
- ✦ The Alarm can be reset by the user by using the Control Panel keypads in case that it's not reset the time out 2min/15min according Dipswitch#4 selection – see Table 3.
- ✦ Arm/Disarm Indication by Beeps/ Flash (Dipswitch Selection)-See Table 3
- ✦ Battery test generate every 4 hours.
- ✦ Low Battery Indication by Beeps/Flash (Depends on Di[pswitch Selection of 2&3)-See Table 3.
- ✦ Tamper protected (Cover and Back tamper).
- ✦ Signal transmitted to Transceiver: Synchronization, Acknowledge, Tamper and Low battery.
- ✦ The Siren can be assigned to Area A or Area B (only when using BUS mode) by Dipswitch Selection –See Table 3

# Unit Connection Diagram

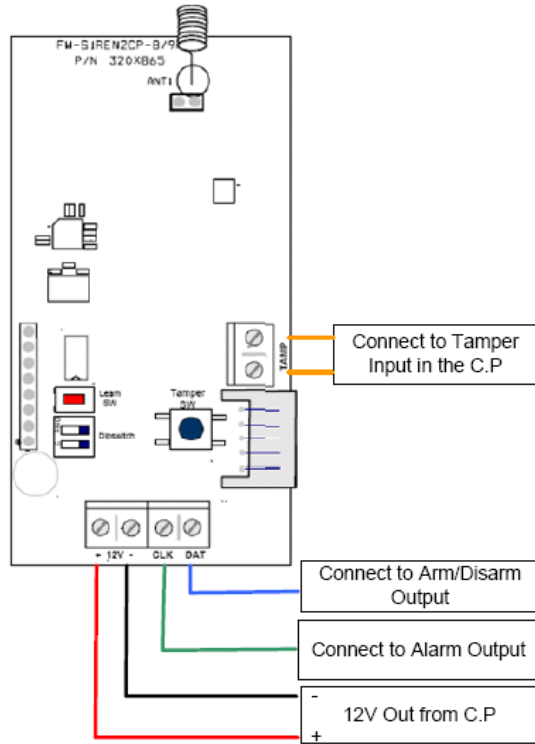

**Figure 1: Standalone Mode Connection**

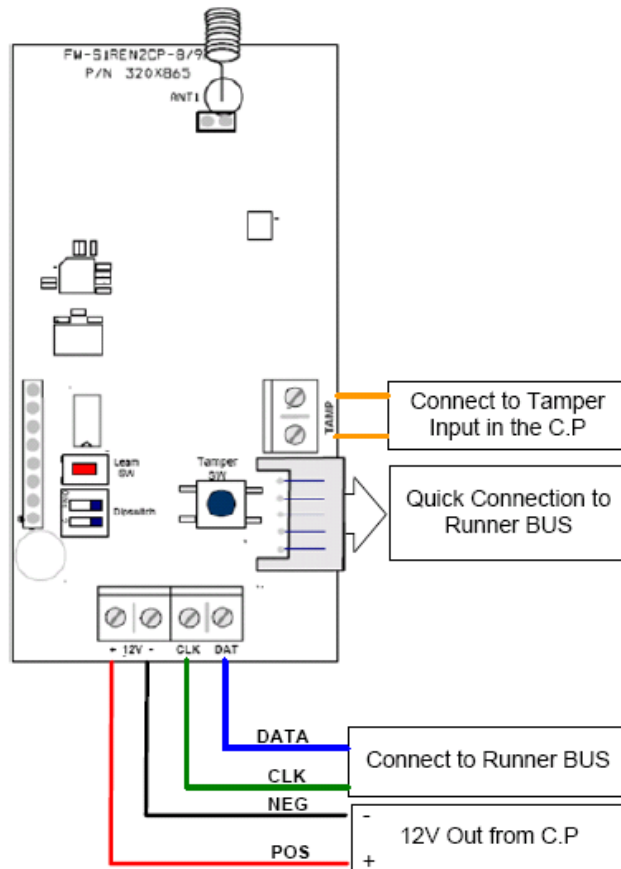

**Figure 2: BUS Mode Connection**

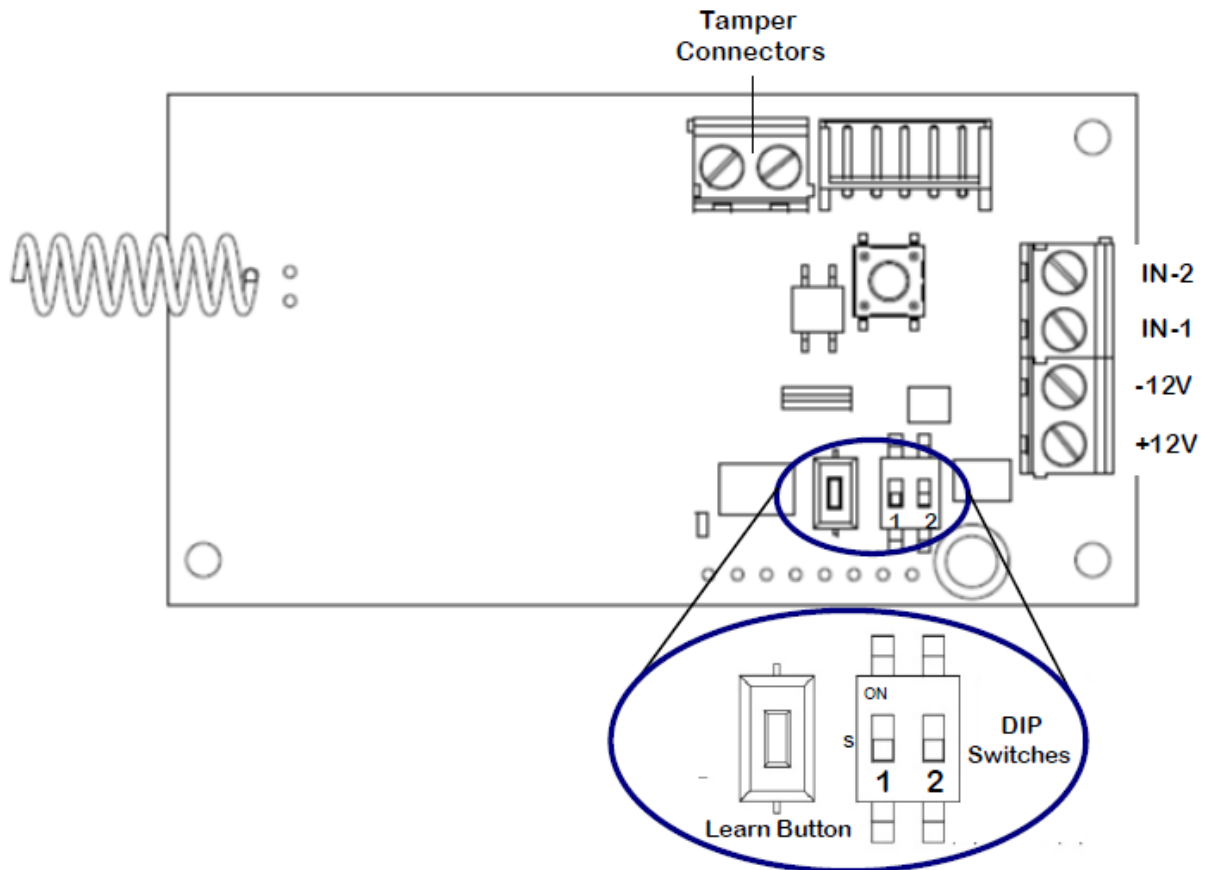

## Physical Locations

### Transceiver Unit

Figure 3: Transceiver Locations Diagram

Table 1: Dipswitch Setting

Dipswitch Setting	ON	OFF
DIPSWITCH 1	BUS Mode	Standalone Mode
DIPSWITCH 2	Tamper on board Disable	Tamper on board Enable

Table 2: Input Configuration

Operating Mode	BUS Mode	Standalone Mode
CLK	CLK	IN-1: Alarm (Active Low)
DAT	DATA	IN-2: Arm/Disarm (Active Low)

## Siren Unit

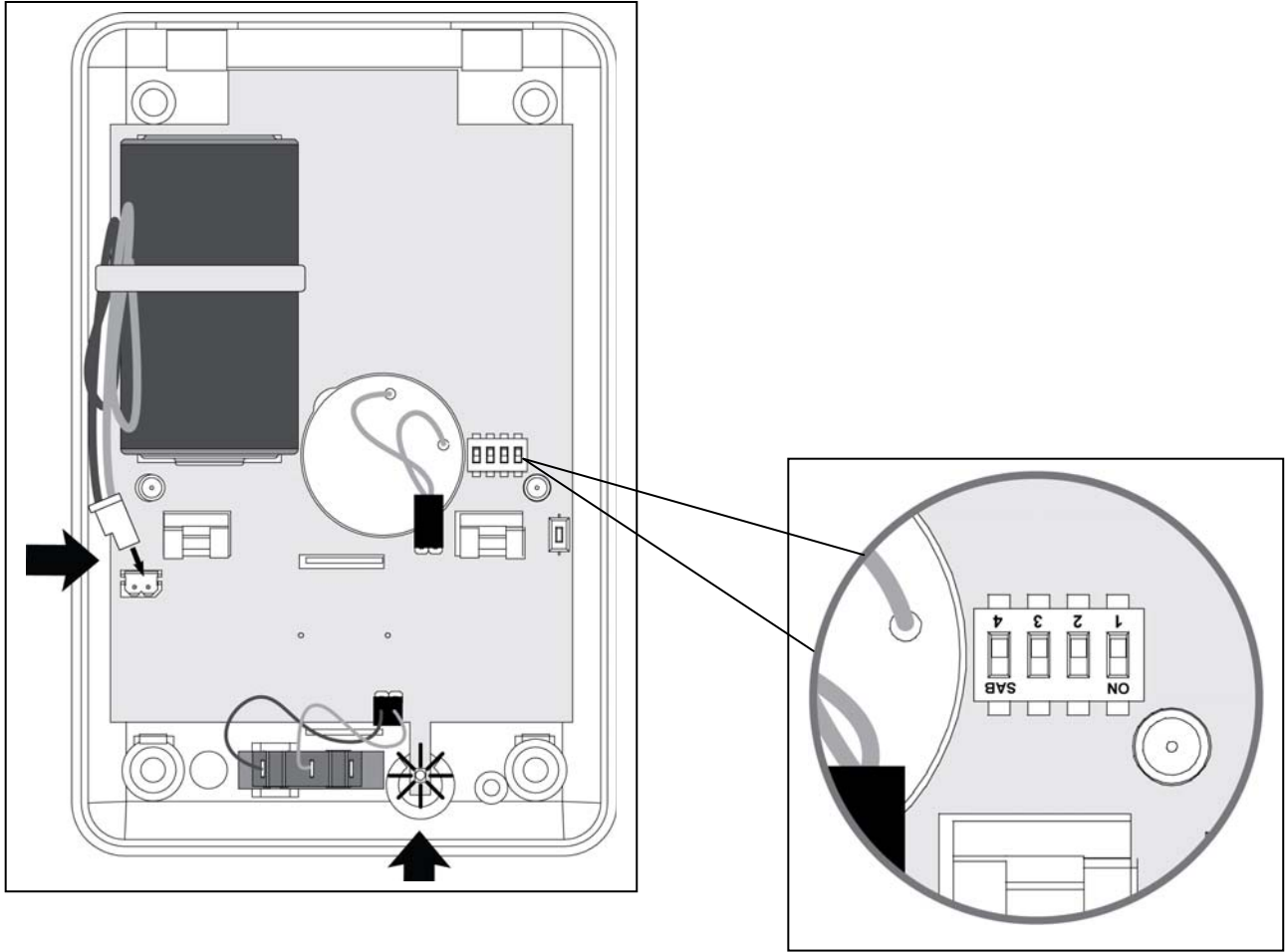



Figure 4: Siren Unit Diagram

Siren's Dipswitch MODE SET-UP		
Dipswitch No.	Function if = 0 (Open)	Function if = 1 (Close)
1	Area A Group	Area B Group (BUS Mode only)
2	NO Flashes with ARM/Disarm	Flashes appear with ARM/Disarm Arm: 2 Flashes (@LOW BAT 3+3 Flashes) Disarm: 1 Flash (@LOW BAT 2 Flashes)
3	NO Beeps with ARM/Disarm	Beeps sound with ARM/Disarm Arm: 2 Beeps(@LOW BAT 3+3 Beeps) Disarm: 1 Beep (@LOW BAT 2 Beeps)
4	2 Min Time out	15 Min Time out

Table 3: Dipswitch set-up.



Mnemonic	Description
<PROG>	PROGRAM key.
<ENTER>	Enter key.
	Press key or enter parameter

















## Learning the Transceiver in the C.P as Zone (BUS Mode)

### **Notes:**

The learning between the Transceiver to the Siren Units should be performing before the installation of the Siren Units.



It's important to locate the Siren at least 2 meter distance from the transceiver.

It's recommended to install the transceiver at least 2 meter from the FW-Receiver, if there is any.

	Command or Instruction	Description
1	Set DIPSWITCH#1 to ON	Supported only by Runner4/8
2	Set DIPSWITCH#2 ON – Transceiver Tamper enabled OFF – Transceiver Tamper disabled	If the Transceiver is installed with it's original plastic box select DIPSWITCH#2 to OFF
3	Power OFF the Control Panel	
4	Wired the connection between the Tansceiver to the C.P accordingly.	See figure 3
5	Power up the panel	
6	Ensure system is disarmed	
7	 <PROG>  code  <ENTER>	Factory default code 000000
8	 <PROG>  122  <ENTER>  Zone (1 to 16)  1  5  <ENTER>	Select spare zone for the Siren Indications (prefer Zone 16). Option 1 for Zone 16 activation and option 5 for radio device selection.
9	 <PROG>  164  same zone as above  <ENTER>	Select Radio Learn mode and wait for mode to change.
10	 <ENTER>	Start learning process.
11	On Transceiver  <Learn/Test> button	On the Transceiver, press the Learn/Test button. The Control Panel Starts short beeps. The beeping stops as soon as the device is registered (learned).

## Learning the Sirens into the Transceiver (BUS and Standalone)

Up to 8 siren units can be activated by single Transceiver. In BUS Mode, these sirens can be divided to two groups (A&B) for activating their sirens (by receiving two separate activation controls).

	Instruction	Description
1	Place the Siren Units on a flat surface	To verify back tamper is closed.
2	Connect Piezo siren cable	
3	Connect battery cable	The Siren will beep once and then the LED power will blink for a period of 30 seconds, please wait to the end of the blinking before activating or learning.
4	If it's BUS Mode Set Dipswitch#1 According Table 3	If it's Standalone or BUS Mode with assignment to Group A the Dipswitch#1 should be off.
5	Set Dipswitch 2 and 3 according to Table 3	Low Battery indication's beeps and flashes will be "on" no matter what the status of Mode Dipswitch 2 and 3.
6	Transceiver  <Learn/Test>	On the Transceiver press Learn/Test button. Blue LED on Transceiver starts flashing.
7	Siren  <Learn>	On the siren press Learn button. Blue LED on the Transceiver turns to solid "ON" for three seconds and then turns OFF. The Siren is learned by the Transceiver.

## Function Testing after learning.

After the learning completed and before the installation verify that the Siren Units are functioning as defined.

- Perform Arm/Disarm verify beep/flash indications.
- Perform an Alarm; verify Piezo and Flash are activated.
- Perform Alarm Reset via the Keypad by User pin code.

**Note: In both modes BUS /Standalone verify all connections are set before the test.**

## Installing the Transceiver

1. Choose a central location for the installation of the Transceiver to insure radio coverage to all the Siren Units.
2. Open the Screw (See Figure-6) and open the cover.
3. Place the unit on the installation surface and mark out the four screw holes.
4. Use a 6 mm bit to drill the holes.

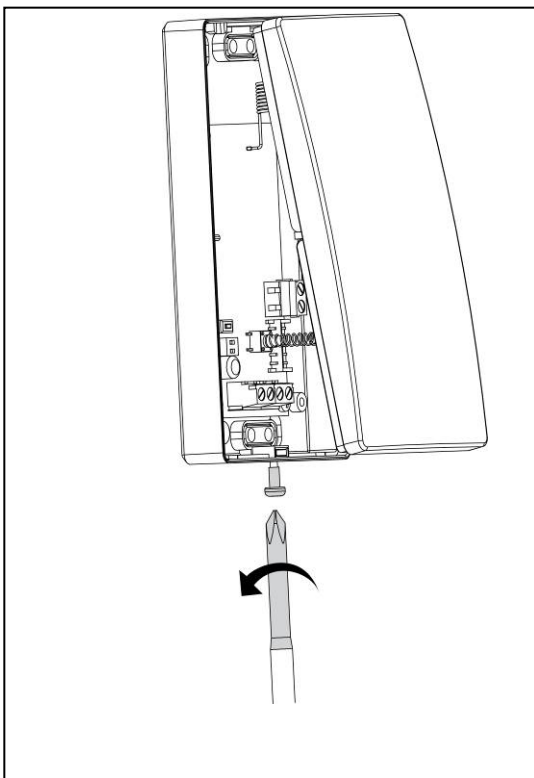

**Figure 5: Open Transceiver Unit**

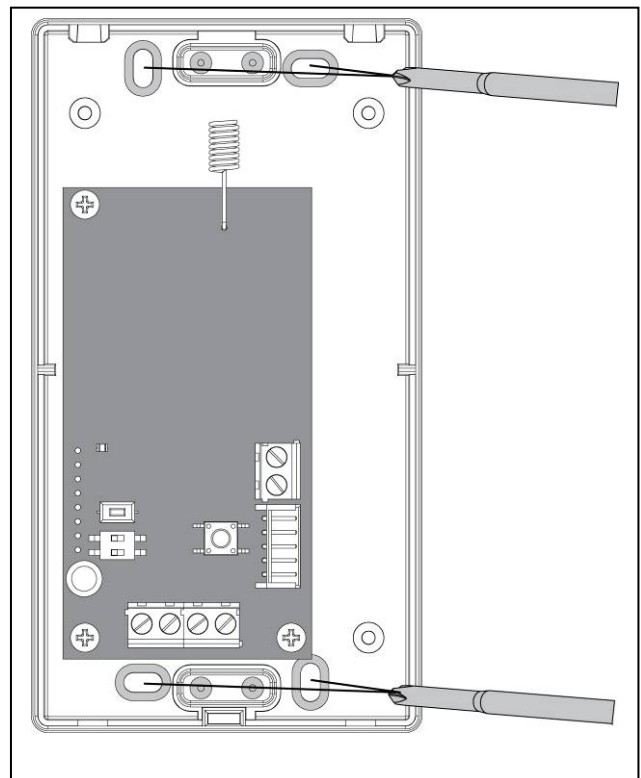

**Figure 6: Transceiver Installation**

5. Power-Off the control panel.
6. Wired the Transceiver to the Control Panel.
7. Power-On the Control Panel.
8. Check the functionality of the system before installing the Siren Units.

## Installing the Siren Units

A Transceiver can control up to 8 sirens. It is recommended that the units be installed on a flat surface in a prominent location.

◆ **To install the siren in each location:**

1. Choose a location for each one for the installation of each siren units. Make sure that there is Radio coverage to this location from the Transceiver.  
Place the Siren Units high enough off the ground in order to make them inaccessible to passers-by and well within the wireless range of the cluster Transceiver
2. Remove the LED cover by a tool.

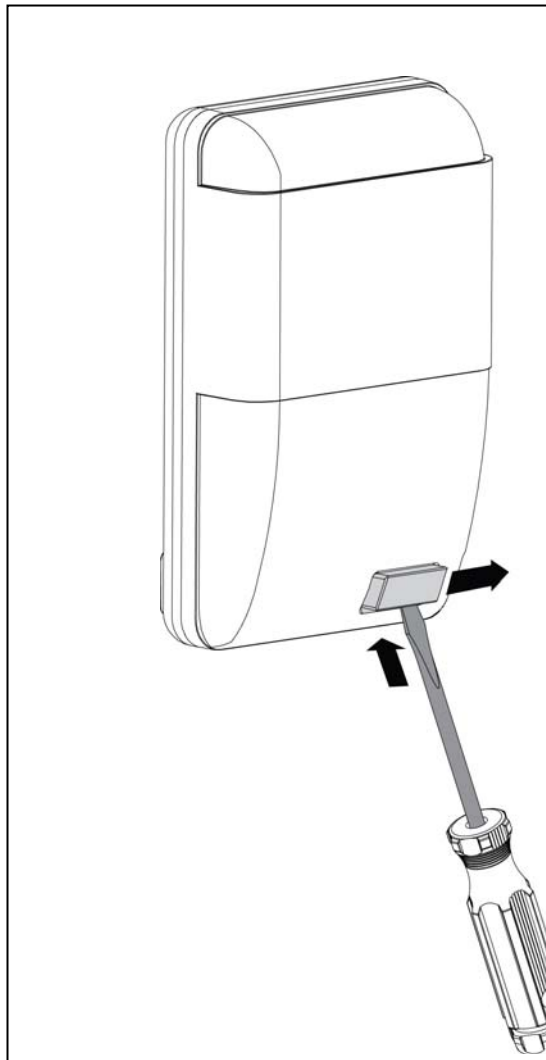

**Figure 7a: Remove the LED covers**

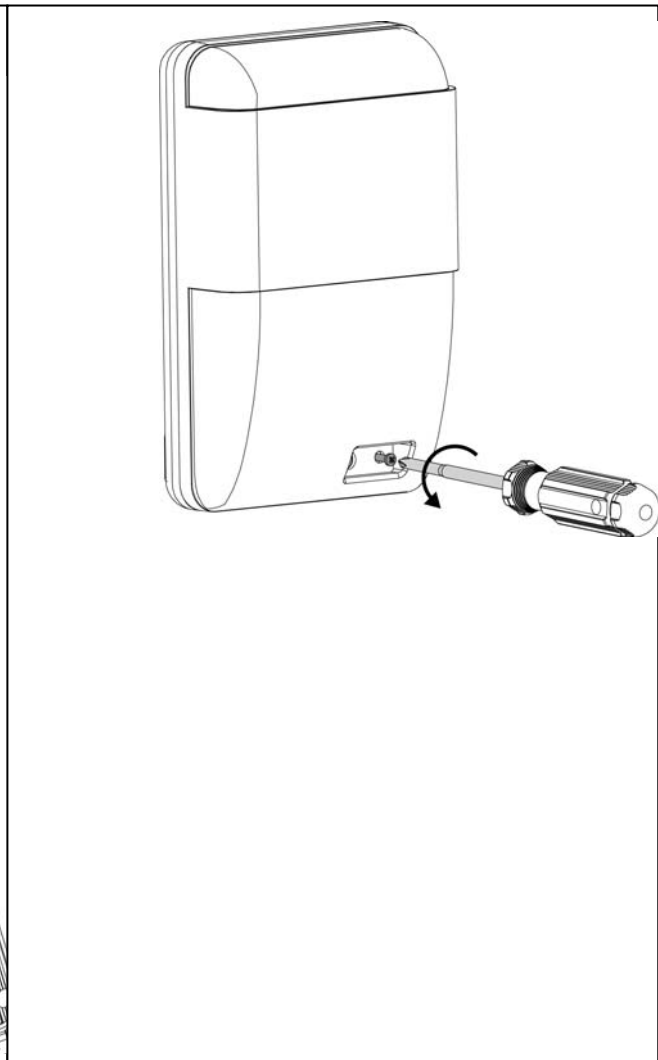

**Figure 7b: Open the screw**

3. Open the screw.
4. Place the unit on the installation surface and mark out the four screw holes.

- Use a 6 mm bit to drill the holes

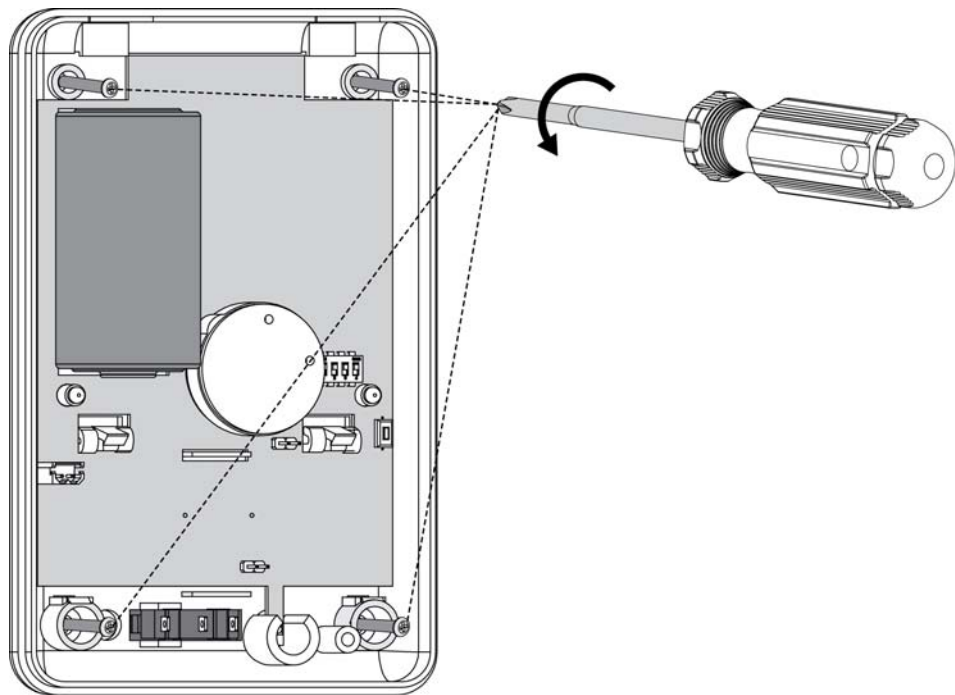

**Figure 4: Installing Siren Unit**

- Fix the unit onto the installation surface.
- Ensure that the Piezo siren is connected to the **Piezo** connector (as shown below).

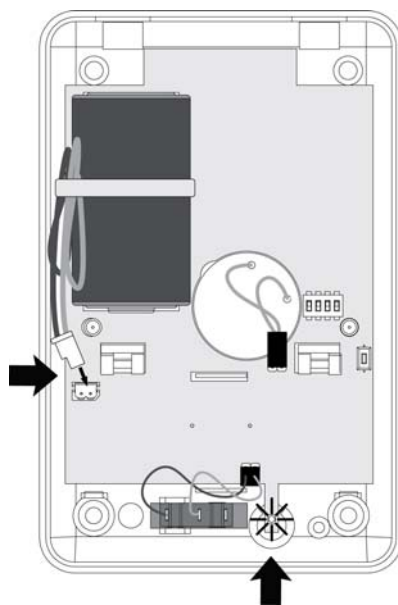

**Figure 5: Battery Connectors**

- Insert the battery into the battery clip and connect it to the **BAT** connector (shown above).



**Note: The battery shall be Installed/replaced by service man**

*The Siren will beep once and then the LED power will blink for a period of 30 seconds, please wait to the end of the blinking before activating or learning.*

## Low Battery Indication

The battery is tested every 4 hours and after power-up.

When the siren battery is low more beeps are added to the ARM/Disarm beeps in order to indicate the LOW BAT condition of the siren unit. When arming the siren there are 3 beeps, short pause and another 3 beeps instead of two beeps and when disarming the siren there will be 3 beeps instead of one.

This Low Battery indication's beeps and flashes will be "on" no matter what the status of Dipswitch 2 and 3.

In Bus Mode the Low Battery status will be reported to the Control Panel via the BUS and will be indicated as Device's Low Bat Alarm.

## Changing the Siren Battery

### To change the siren battery:

- Open the Siren Unit as shown in Figure 7.
- Disconnect the battery and replaced it by fresh one.
- Verify Low Bat restored.



**Note: The battery shall be Installed/replaced by service man**

*The Siren will beep once and then the LED power will blink for a period of 30 seconds, please wait to the end of the blinking before activating or learning.*

## Erasing the Siren Memory.

In case of Transceiver need to be replaced, the memory of the Siren Units should be cleared. To clear the Siren Units memory, follow the next steps.

- Turn off the power of the Siren Units.
- Press continuously on the Learn button and then power-up the Siren Unit.
- Keep pressing until the Power LED will blink fast 3 times.
- Release the Learn Button
- Memory clear complete.

## Erasing the Transceiver Memory.

In case of replacing or removing one Siren Unit from the installation, the memory of the Transceiver and other Sirens units should be cleared.

To clear the Transceiver memory, follow the next steps:

- Turn off the power of the Transceiver.
- Press continuously on Learn button and then power-up the Transceiver.
- Keep pressing until the Blue LED will blink fast 3 times.
- Release the Learn Button
- Memory clear complete.

## Specification: Siren Unit

FW-Siren Specification (External Unit)	Value
Sound Pressure Level	More then 100dB
Siren Tone	Yelp
Frequency Range	2700 ±500 Hz
Flash Light	LED
Power Supply Voltage	None
Current consumption	<p><b>Standby:</b> 110uA ±10uA@ Battery operation</p> <p><b>Alarm:</b> Average: 400mA @ Battery operation. Max: 600mA peak@ Battery operation.</p>
Power Supply current limitation	Up to 1A
Maximum Power	Average :3W
Siren Alarm Period	2 min/15 min (According the status of Dipswitch#4)
Low Battery Level	2.8V
Low Battery Indication	LED Flash @ Arm/Disarm (According the status of Dipswitch 2&3)
Arm/Disarm Indication	<ul style="list-style-type: none"> <li>• LED Flash : Arm-1, Disarm-3</li> <li>• LED Flash with Beeps : Arm-1, Disarm-3</li> </ul> (According the status of Dipswitch 2&3)
Supervision	Sync signal every 1 min.
Tamper Switch	Normally Closed. After power up the Tamper will activate only after the second opening and then Activate the Piezo for 2 min or till reset by the C.P.
Battery Life	> 4 Years (Based on 2 min Piezo operation/month)
Material	External Box: ABS. (2mm thick).
Dimensions of unit	L=155mm x W= 100mm x H= 48mm
Weight (Without Battery)	1.2 Kg
Operating temperature range	-10oC to +50oC
Case Protection Level	Indoor Unit

## Specification: Transceiver Unit

Transceiver Specification (Remote)	Value
<b>Power Supply</b>	9V-14V DC
<b>Current Consumption</b>	Receive:30mA±5mA Transmit:40mA±5mA
<b>Max power</b>	1W
<b>Operating temperature range</b>	-10oC to +50oC
<b>Ambient temperature, storage</b>	-20oC to +70oC
<b>Inputs</b>	IN-1: Trigger Alarm. IN-2: Trigger Key Arm/Disarm BUS Connection via Fast Connection or Terminals
<b>Outputs</b>	Tamper Out Terminals: Normally Closed Active open while Tamper at the Transceiver or Siren unit is open.
<b>Indication</b>	Blue LED indicate Rx/TX
<b>Tamper</b>	Connected by hardware to TAMP OUT output. Can be ignored(see Dipswitch 2)
<b>Dipswitch 2</b>	Dip#1 : Define the Mode operation #1 On: BUS Mode. #1 OFF: Universal Mode  Dip#2 : Define Tamper #1 On: Without Tamper #1 OFF: With Tamper
<b>RF Frequency 8F/9F</b>	868.35MHz / 916.5MHz
<b>RF Range</b>	>500m at open space