



SH-TEMP-PRB-XT

TWO WAY WIRELESS
TEMPERATURE SENSOR



INSTRUCTION MANUAL
P/N 7105965 Rev B (D.Z)

PRODUCT FEATURES

The SH-TEMP-PRB-XT is an advanced temperature sensor with integrated RF transceiver designed to be a fully supervised low-current device.

The SH-TEMP-PRB-XT is a part of the FREEWAVE2 devices that uses an advanced 2way RF transceiver combined with an intelligent communication protocol.

Temperature over the external sensor by using unique cord with NTC connected to the external input (e.g. measure freezer internal temperature)

Temperature measurements are transmitted to the control panel.

Each SH-TEMP-PRB-XT has a unique factory set ID code (24bit) which by registration is set into memory of the paired FREEWAVE2 TRANSCEIVER, enabling more secured communication and devices be remotely controlled from a specific transceiver.

DETECTOR OPENING

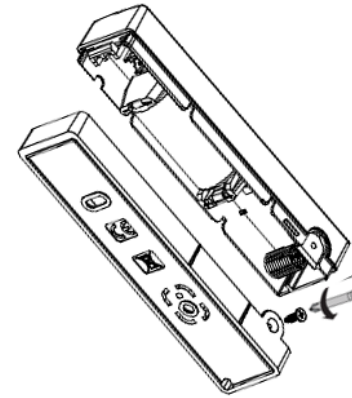

Figure 1

Unscrew the holding screw and remove the front cover. Gently twist the PCB board to disengage it from the plastic cover.

KNOCKOUT HOLES

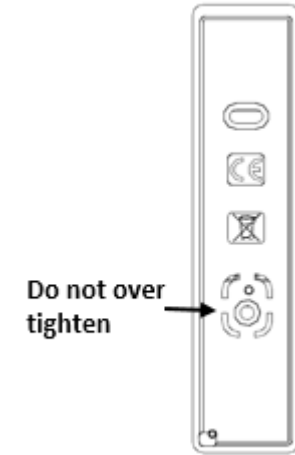

Figure 2

Detector mounting:

Place the screws and make sure you tighten the tamper screw (middle screw) easily, so the back tamper switch will press the switch successfully when the PCB placed back.

DEVICE OVERVIEW

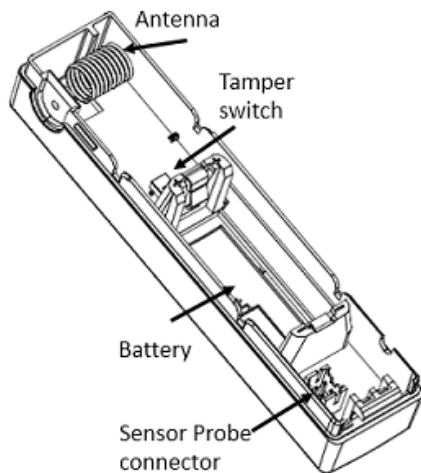

Figure 3

PAIRING PROCESS

For pairing process, please refer to your control panel instructions.

To pair your device with Control panel, please proceed as follows:

1. Login installer mode via the "Installer Webpage"
2. Go to "Zones" and select the zone # you want to learn
3. Add Zone -Type "ISM", insert device SN. (device's ID)
The system automatically detects the device type "Temperature"
4. Set the detector configuration:
"Refrigerated storage" - Pre-set temperatures
"Room temperature" - Pre-set temperature
"Custom" - Temperature setting according to customer requirement, Please see more details in this manual section THRESHOLD SETTINGS.
save configuration.
5. Place a battery as instructed in Figure 4 and wait until the Red / Green LED stops blinking.
6. The device should register to the Control Panel.
7. When registration process is successfully completed, the Green LED will constantly light ON for 3 seconds and then turn OFF.
8. If Green LED continues flashing more than 5 minutes and stopped, please check the SH-TMP SN, remove battery and repeat steps 3, 4 and 5.
9. In order to receive alarm of High/Low temp' and warning, the working mode should set "24 hour auto reset".
10. Please see **THRESHOLD SETTINGS** for device configuration

BATTERY INSERTION

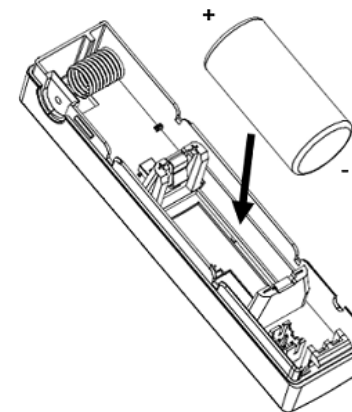

Figure 4

Insert the supplied battery into the battery by respecting polarity. LED on device will start blinking. Please refer to above para "Learning process" for device registration.

SENSOR LED DESCRIPTION

GREEN / RED Led flashes 6 times alternately:

Sensor has been successfully registered into the control panel. The cover may be placed back and closed.

GREEN Led blinks 20 times:

Device is not registered into the control panel. Please refer to above para. "Pairing Process" for pairing instructions.

RED Led blinks continually (over 20 seconds):

Battery voltage is critically low. The device may not work correctly. Please refer to para. "Battery Replacement" below.

SELECT MOUNTING LOCATION

It is recommended to mount the Temperature sensor vertically on a flat area to get maximum range.

As the device is a wireless transceiver, and in order to take full advantage of its sophisticated operation, do not install the SH-TEMP-PRB-XT in areas where large metal objects or surfaces can interfere with the transmission of signals.

Do not place on a ferromagnetic surface.

THRESHOLD SETTINGS

In custom working mode, 3 temperature thresholds can be set: **high, normal and low**.

Warning alert Time Value - The time (minutes) when the temperature should be above the normal threshold before the "Attention Temperature Alarm" is reported.

A high and low temperature alarm will be report after 3 samples (one sample per minute) beyond the temperature threshold.

Note that a high, Attention or low temperature alarm restore report will only be received after 3 samples (one sample per minute) when the temperature is back between the normal and low threshold.

The device provides a temperature update every minute trough the device status report (supervision)

see example Figure 6

WARRANTY POLICY CERTIFICATE

Crow warrants these products to be free from defects in materials and workmanship under normal use and service for a period of 24 months from the last day of the week and year whose numbers are printed on the printed circuit board inside these products.

Subject to the provisions of this Warranty Certificate, during the Warranty Period, Crow undertakes, at its sole discretion and subject to Crow's procedures, as such procedures are form time to time, to repair or replace, free of charge for materials and/or labor, products proved to be defective in materials or workmanship under normal use and service. Repaired products shall be warranted for the remainder of the original Warranty Period.

All transportation costs and in-transit risk of loss or damage related, directly or indirectly, to products returned to Crow for repair or replacement shall be borne solely by the Purchaser.

This Warranty Certificate does not cover products that is defective (or shall become defective) due to: (a) alteration of the products (or any part thereof) by anyone other than Crow, (b) accident, abuse, negligence, or improper maintenance, (c) failure caused by a product which Crow did not provide, (d) failure caused by software or hardware which Crow did not provide; (e) use or storage other than in accordance with Crow's specified operating and storage instructions.

There are no warranties, expressed or implied, of merchantability or fitness of the products for a particular purpose or otherwise, which extend beyond the description on the face hereof.

This limited Warranty Certificate is the Purchaser's sole and exclusive remedy against Crow and Crow's sole and exclusive liability toward the Purchaser in connection with the products, including without limitation - for defects or malfunctions of the products. This Warranty Certificate replaces all other warranties and liabilities, whether oral, written, (non-mandatory) statutory, contractual, in tort or otherwise.

In no case shall Crow be liable to anyone for any consequential or incidental damages (inclusive of loss of profit, and whether occasioned by negligence of the Crow or any third party on its behalf) for breach of this or any other warranty, expressed or implied, or upon any other basis of liability whatsoever.

Crow does not represent that these products can not be compromised or circumvented; that these products will prevent any person injury or property loss or damage by burglary, robbery, fire or otherwise; or that these products will in all cases provide adequate warning or protection.

Purchaser understands that a properly installed and maintained product may in some cases reduce the risk of burglary, fire, robbery or other events occurring without providing an alarm, but it is not insurance or a guarantee that such will not occur or that there will be no personal injury or property loss or damage as a result. Consequently, Crow shall have no liability for any personal injury; property damage or any other loss based on claim that these products failed to give any warning. If Crow is held liable, whether directly or indirectly, for any loss or damage with regards to these products, regardless of cause or origin, Crow's maximum liability shall not in any case exceed the purchase price of these products, which shall be the complete and exclusive remedy against Crow.

BATTERY REPLACEMENT

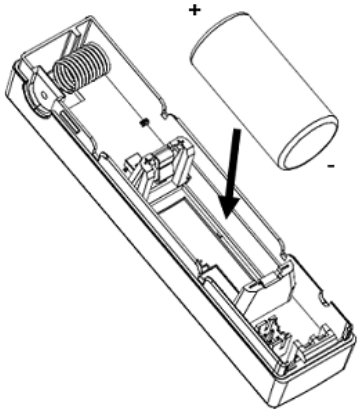

Figure 5
The battery can be replaced by the user.

The battery must be replaced by 3V Lithium

Models such as
GP CR123A

CAUTION

RISK OF EXPLOSION
IF BATTERY IS REPLACED BY DIFFERENT TYPE / MODEL.

DISPOSE USED BATTERIES
ACCORDING TO ITS INSTRUCTIONS

SPECIFICATION

Detection Method	External Wired Probe Sensor
ISM Radio	2GFSK
Operating Frequencies	868MHz
Identification	Unique ID serial number – 24 bit
Events Transmission	Alarm, Tamper, Supervision, Low Bat, Keep Alive.
Supervision Time	1 min preprogrammed (not configurable)
Transmission Range	500m in open space
Battery	3V Type CR123A Lithium
Battery life	Up to 5 years
Current Consumptions	Standby ~20 µA Receive mode ~55 mA Transmit mode ~16 mA
	Low Bat 2.5V Cut Off 2.2V
Tamper Switch	Front Cover and Wall Removal
Operating temperature	-10°C to +55°C
Probe Temperature Measurement	-40°C to +105°C
Dimensions	98.6mm x 23.2mm x 21.6mm
Weight (incl. battery)	45 gr.

External probe sensor accuracy range:
 From -40°C to -20°C accuracy is ±1°C
 From -20°C to +75°C accuracy is ±0.5°C
 From +75°C to +105°C accuracy is ±1°C

ACCURACY ±1°C	ACCURACY ±0.5°C	ACCURACY ±1°C
-40°C	-20°C	+105°C

THRESHOLD SETTINGS Example

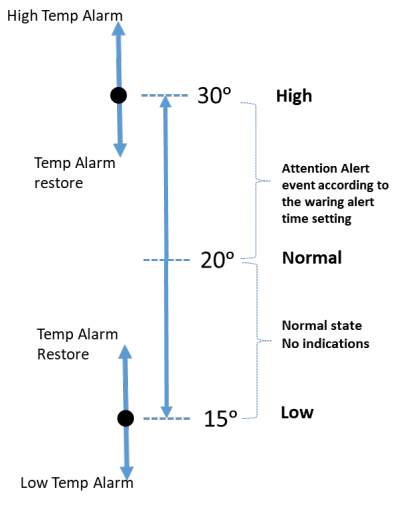



Figure 6

Get Cache Data

The system can provide temperature values log up to the last 48 hours.

1. Enter the installer mode and go to overview level.
2. Locate the Temperature detector zone number and click the statistic button located in the zone statistics column.
3. Click the Get Cached data button and wait for three steps to complete successfully.
4. Click the download button to download the file, review the file.



sales@crow.co.il
support@crow.co.il

www.thecrowgroup.com