

# FW2-FLOOD-S

FW2- FLOOD S 8F/9F  
Wireless Flood Detector



## INSTALLATION INSTRUCTIONS

P/N 7105389\_A

## INTRODUCTION

The FW2-FLOOD is an advanced Flood sensor with integrated RF transceiver designed to be a fully supervised low-current device. The FW2-FLOOD is a part of the FREEWAVE2 which is a supreme wireless line of devices that uses an advanced 2way RF transceiver combined with an intelligent communication protocol. A built-in terminal connection for an external wired sensor applies in this device.

FW2-FLOOD uses smart message control, which verifies that all messages are successfully transmitted, so that no Flood event will be uninformed to the system.

Each FW2-FLOOD has a unique factory set ID code (24bit) which by registration is set into memory of the paired FREEWAVE2 TRANSCEIVER, enabling more secured communication and devices to be remotely controlled from a specific transceiver.

## FEATURES

- State-of-the-art 2 way wireless security system
- Freewave2 advanced & secured RF protocol
  - GFSK with 5 frequencies & LBT
- Low current Technology
- Powered by a single 3V Lithium battery
- Battery life: more than 5 years
- Frequency: 8F (868 MHz), 9F (916 MHz)
- Tamper Open/Close transmission
- Supervision transmission
- Battery status send on every transmission
- Range up to 500m on open space.
- Unique ID number
- Front and back tamper.
- Alarm trigger by the wired contact sensor which is located at the end of the wired cable
- Wired terminal for wire cable sensor connection
- Bi-Color LED indications

## OPERATION

The Wireless Flood detector transmits the following events data:

**SUPERVISION** - a periodical transmission time which is configurable indicates detector's presence.

**ALARM** - Alarm transmission triggered by Golden contacts pins located at the end of the external cable. The fluid has to reach the two exposed golden contacts

**LOW BAT** - Whenever the battery reaches a pre-set low level (~2.4V) Battery Low signal will be sent with the next scheduled message (Supervisor, Alarm, etc.).

**TAMPER** - Whenever the FW2-FLOOD cover is removed or tore off wall, a message will be transmitted with "Tamper" signal.

## FIG. 1 - REMOVAL OF FRONT COVER

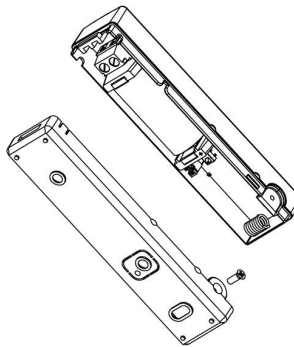

## FIG. 2 - BATTERY PLACEMENT

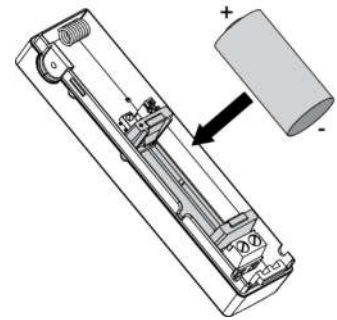

## Fig. 3 - CIRCUIT LAYOUT

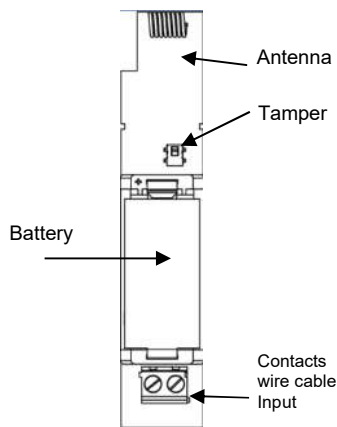

## FIG. 4 - MOUNT FORM

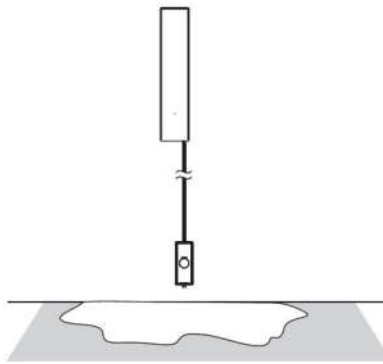

## Fig. 5 - KNOCKOUT HOLES

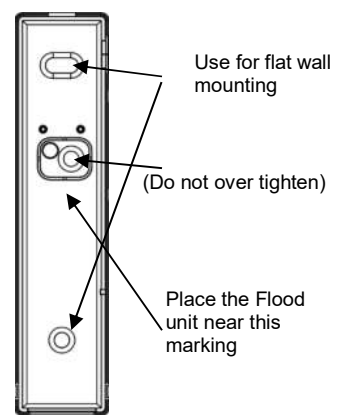

## MOUNTING THE DETECTOR

Before starting to install and work with this device, please read the Safety Instructions.

### 1. Scope of delivery

FW2-FLOOD Wireless Unit, Flood Sensor Unit, (a) Screws for mounting the Units, (b) plugs, (c) Screw for locking the cover, (d) Battery.

### 2. Installation Instruction

- Mount the Flood sensor unit.
- To remove the front cover, unscrew the holding screw (Fig.1), insert a flat screwdriver in the slot between the front and the bottom while pushing and twisting it gently until the front cover is disengaged. (Fig. 1)
- Remove Printed Circuit board from the unit base
- Mount the base at 60cm above the sensor (Fig. 4),
- place all 3 screws (Fig.5) and make sure you tighten the tamper screw (the middle screw) easily, so the back tamper switch will press the switch successfully when PCB is placed back - over winding may result in false mechanical adaptation and lack of tamper press

## MOUNTING THE DETECTOR

- Install the Printed Circuit board back into the base of the wireless unit.
- Connect the two wires coming from the sensor to the Terminal block (Fig 4). The fluid has to reach the two exposed Golden contacts at the bottom side of the sensor in order to give an alarm

Use only the supplied screws and plugs.  
**H.** Install battery (Fig.2) according to the polarity (-) (+) indications.

Risk of explosion if battery is replaced by an incorrect type.

- Use only batteries delivered by the supplier.
- Place the cover by inserting it back in the appropriate closing pin and screw the holding screw.

## ID REGISTRATION

### For Shepherd series

- Refer to the system installation instructions and follow the "learning" detector IDs via web installer page.
- Select Zone #, Add Zone -(Reminder: insert Link Type "ISM", device's ID, Device Type "Flood Detector" in zone level.)

- Set the supervision time accordantly, ( default: 7 Min .)

- the Working Mode parameter will be set to " 24 HOUR FLOOD ZONE " automatically.

- Save Configuration.
- Place battery as instructed & wait until LED stops blinking.

### Note the LED indications on the device:

- **Green/Red LED flashes alternately** - for 6-9 sec FLOOD was registered successfully.
- **Green LED blinks periodically** - Device was not signed into system, Repeat registration process
- **Red LED blinks** - for over 20sec Battery voltage is critically low. Replace battery

**ID REGISTRATION (cont.)****For SERENITY**

Refer to the system installation instructions and follow the "learning" detector IDs.  
Place battery as instructed & wait until LED stops blinking.  
Make sure that the system is on learning mode.  
Generate a transmission by pressing and releasing tamper switch of the FW2-FLOOD.

- **Green/Red LED flashes alternately** – for 6-9 sec, FLOOD was registered successfully.
- **Green LED blinks periodically** – Device was not signed into system, Repeat registration process
- **Red LED blinks** – for over 20sec  
Battery voltage is critically low. Replace battery

**ALARM TRANSMISSION TEST**

Shorting and disconnecting of Flood sensor contacts pins unit enables the alarm transmission test feature.

To check this function it is necessary to verify that the FREEWAVE2 control panel displays the following message:

**24 hour alarm, open**

The message appears when shorting the flood sensor contacts pins unit and disappears while disconnecting the flood sensor contacts pins back (X = zone number from which the message received).

**TECHNICAL SPECIFICATIONS**

Data Protocol	FreeWave2
Modulation Type	GFSK (1 Frequency)
Frequency	868.35MHz / 916.5 MHz
Identification	Unique ID serial number – 24 bit
Event Transmission	Alarm, Tamper, Supervision, Low Bat, Supervision
Detection Method	External golden contacts pins device
Range in open space	500m
Battery	Lithium. 3V Type: CR123A Size: 2/3AA
Battery life	>5 years ( 10 activation per day)
Current Consumptions	Standby ~3 µA Receive mode ~29 mA Transmit mode~38 mA Transmit Power <14dBm
Low Battery	~2.4Vdc
Transmit power	~10dBm
Tamper Switch	Front Cover Removal; Back Tamper
Operating temperature	10°C to +55°C
Dimensions	97mm x 23mm x 22mm
Weight (inc. battery)	40 gr.

**CROW ELECTRONIC ENGINEERING LTD. ("Crow") - WARRANTY POLICY CERTIFICATE**

This Warranty Certificate is given in favor of the purchaser (hereunder the "**Purchaser**") purchasing the products directly from Crow or from its authorized distributor.

Crow warrants these products to be free from defects in materials and workmanship under normal use and service for a period of 24 months from the last day of the week and year whose numbers are printed on the printed circuit board inside these products (hereunder the "**Warranty Period**").

Subject to the provisions of this Warranty Certificate, during the Warranty Period, Crow undertakes, at its sole discretion and subject to Crow's procedures, as such procedures are from time to time, to repair or replace, free of charge for materials and/or labor, products proved to be defective in materials or workmanship under normal use and service. Repaired products shall be warranted for the remainder of the original Warranty Period.

All transportation costs and in-transit risk of loss or damage related, directly or indirectly, to products returned to Crow for repair or replacement shall be borne solely by the Purchaser. Crow's warranty under this Warranty Certificate does not cover products that is defective (or shall become defective) due to: (a) alteration of the products (or any part thereof) by anyone other than Crow; (b) accident, abuse, negligence, or improper maintenance; (c) failure caused by a product which Crow did not provide; (d) failure caused by software or hardware which Crow did not provide; (e) use or storage other than in accordance with Crow's specified operating and storage instructions.

There are no warranties, expressed or implied, of merchantability or fitness of the products for a particular purpose or otherwise, which extend beyond the description on the face hereof. This limited Warranty Certificate is the Purchaser's sole and exclusive remedy against Crow and Crow's sole and exclusive liability toward the Purchaser in connection with the products, including without limitation - for defects or malfunctions of the products. This Warranty Certificate replaces all other warranties and liabilities, whether oral, written, (non-mandatory) statutory, contractual, in tort or otherwise.

In no case shall Crow be liable to anyone for any consequential or incidental damages (inclusive of loss of profit, and whether occasioned by negligence of the Crow or any third party on its behalf) for breach of this or any other warranty, expressed or implied, or upon any other basis of liability whatsoever. Crow does not represent that these products can not be compromised or circumvented; that these products will prevent any person injury or property loss or damage by burglary, robbery, fire or otherwise; or that these products will in all cases provide adequate warning or protection.

Purchaser understands that a properly installed and maintained product may in some cases reduce the risk of burglary, fire, robbery or other events occurring without providing an alarm, but it is not insurance or a guarantee that such will not occur or that there will be no personal injury or property loss or damage as a result.

Consequently, Crow shall have no liability for any personal injury; property damage or any other loss based on claim that these products failed to give any warning.

If Crow is held liable, whether directly or indirectly, for any loss or damage with regards to these products, regardless of cause or origin, Crow's maximum liability shall not in any case exceed the purchase price of these products, which shall be the complete and exclusive remedy against Crow.

**TESTING THE DETECTOR****Walk Test**

**A.** Walk Test can be use in "OVERVIEW" level from programming mode.  
**B.** Start the walk test by pressing the Start walk Test button. **C.** Make a momentary short between the two golden contacts pins of the sensor **D.** Green tick should appear in Check column and momentary red point in Active column on successfully detection.  
**NOTE:** the panel communication led lights flashing red while the system is in a walk test mode

**Tamper Transmission Test**

Pressing and releasing the tamper (push button) enables the TAMPER transmission test feature.

Verify in OVERVIEW, ZONE level indicates "Zone Tamper open" in state column.

Close the Tamper and verify ZONE TAMPER is restored and the state is ready.

**Note:** refresh the web page display in case you don't see the change

**CAUTION !!!**

**RISK OF EXPLOSION IF BATTERY IS REPLACED BY DIFFERENT TYPE / MODEL.**

**DISPOSE USED BATTERIES ACCORDING TO ITS INSTRUCTIONS**

**The battery must be replaced by 3V Lithium battery Size 2/3A**

**Models such as:**

1. VARTA CR123A
2. GP CR123A

**BATTERY REPLACEMENT**

- Remove the front cover.
- Pull out the old battery.
- Install a new battery according to polarity marking.
- After assembling the battery the LED will flash Green then Red alternately between 6-9 seconds. During this time the detector does not function, wait until the LED stop flashing.
- Press tamper for 2 sec and then release it.

**Note:** LED indications

Green/Red LED flashes 6-9 seconds alternately:  
The detector was successfully resync in the system. The cover may be placed back and closed.

  
**Electronic Engineering Ltd**  
12 Kineret St.  
Airport City, 70100 Israel  
Tel. +972 3 9726000  
Fax. +972 3 9726001  
sales@crow.co.il  
support@crow.co.il  
[www.thecrowgroup.com](http://www.thecrowgroup.com)

CROW LATIN AMERICA usa inc.  
7200 NW 19 st.  
Suite 307  
Miami FI 33126, USA  
Tel. +305 513 4001  
Fax. +305 513 4005  
rejane@crowlatinamerica.com  
[www.crowlatinamerica.com](http://www.crowlatinamerica.com)

**These instructions supersede all previous issues in circulation prior to October 2015.**