

1



**FW2-GBD**  
Two Way Wireless  
Shock & Glass Break Detector



**INSTALLATION INSTRUCTIONS**  
P/N7101970 REV.E (D.Z)

2

**INTRODUCTION**

The FW2-GBD is an Omni-directional Two Way Wireless Shock & Glass Break Detector, providing detection coverage of 360° measured from the sensor to the point on the glass farthest from the sensor.

The FW2-GBD detector transmits series of messages for full communication administration (Alarms, Supervision, Tamper Status, Battery Status, Configuration, etc.) as well as test transmission signals.

- 2 Way Wireless communication
- Frequency Band: 868MHz, 915MHz
- Low current Technology
- Powered by a 3 Volt Lithium battery
- Battery life : up to 4 years
- Back Tamper (removal protection)
- Supervision transmission
- Battery status signal transmission
- Unique ID number (24 bits)
- Configurable over-the-air (from Serenity™ panel)

3

**PRODUCT VIEW**

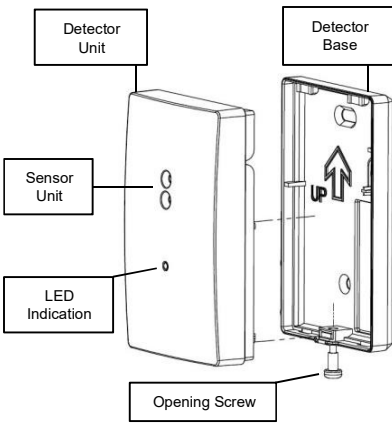

4

**OPERATION**

The FW2-GBD detector transmits the following events:

**SUPERVISION** – A periodical transmission (configurable) indicating detector's presence.

**ALARM** – Alarm transmission triggered by the device indicating Shock and Glass break detection. The Red LED will blink once.

**LOW BAT** – Whenever the battery reaches the low level (2.5V), a Battery Low signal will be sent. When Battery level drops below Cut Off level (2.2V) the device will stop functioning and the Red LED will blink for 10 seconds and then turned Off.

**TAMPER** – Whenever the detector unit is removed from its base or the device is tear off from the wall, a "Tamper" signal will be transmitted to the control panel.

5

**LEARNING PROCESS**

1. Open the screw cover and separate the detector unit from its base by tilting it out as shown in Figure 1.
2. Initiate control panel into "Zone" learning mode (Refer to the control panel manual)
3. Insert battery according to polarity as shown in Figure 2.
4. Green and Red LED will blink for 5 seconds until the learning process is completed.
5. Place the detector base on the mounting location and draw holes on the wall or ceiling as shown on Figure 3.
6. Install the detector base on the wall or ceiling.
7. Replace the detector unit into the base and close the screw (you may cancel Tamper alarm on the panel).

6

**WHERE TO INSTALL ?**

For best false alarm immunity the detector should be located at least 1.2m away from noise sources (televitions, speakers, sinks, doors, etc.).

The detector must always be in direct line of sight of all windows to be protected. It cannot consistently detect glass breaking around corners, in other rooms, etc.

**For Best Detection, Avoid Installing In**

- Lined Rooms, insulating, or deadening drapes
- Rooms with closed wooden shutters inside
- Corners of a room
- Glass airlocks and glass vestibule areas
- Noisy kitchens
- Residential car garages
- Small utility rooms
- Stairwells
- Small bathrooms
- Other small acoustically live rooms

7

**FIGURE 1**

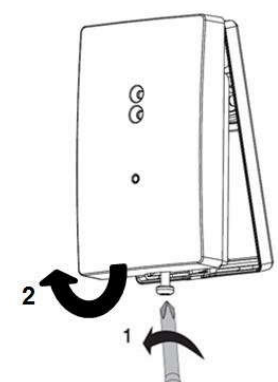

8

**FIGURE 2**

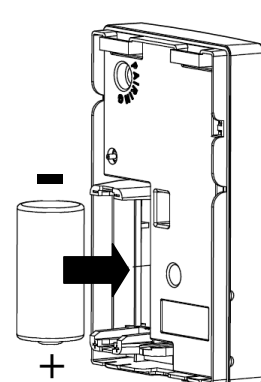

9

**FIGURE 3**

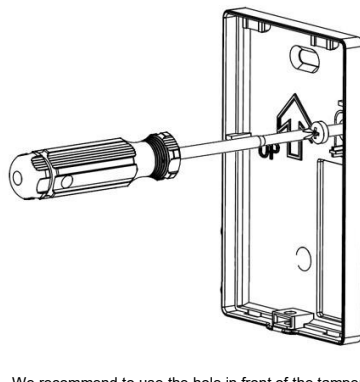

We recommend to use the hole in front of the tamper switch to enable the protection against removal.

10

**RECOMMENDATIONS**

**For Best False Alarm Immunity**

- Don't use where white noise, such as air compressor noise, is present. (A blast of compressed air may cause a false alarm).
- Avoid rooms smaller than 3m x 3m and rooms with multiple noise sources such as small kitchens, glass booths noisy areas, garages, small bathrooms, etc.
- Do not install humid rooms. The FW2-GBD is not hermetically sealed. Excess moisture on the circuit board can eventually cause a short circuit and a false alarm.
- Avoid learning the detector as 24-hour mode, where the detector will be armed even the room is in use. Install the FW2-GBD on a perimeter loop which is armed whenever the door and window contacts are armed.

11

**MOUNTING THE DETECTOR**

**Wall Mounting**

Since the sound of breaking glass travels directionally out from the broken window, the best location for mounting the detector is on the opposite wall – assuming the glass to be protected is within the sensor's range and line of sight. The ceiling and adjoining (side) walls are also good detectors locations.

**Ceiling Mounting**

Mount the detector in any type of ceiling in a location that is in direct line of sight of the windows to be protected. However, since sound travels directionally out from the broken window, a position 2m to 3m into the room provides better detection.

12

**INSTALLATION RANGE**

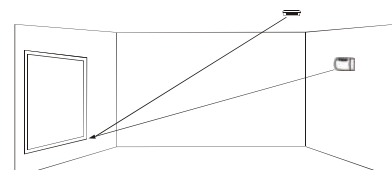

Coverage is measured from the detector to the point on the glass farthest from the detector. The detector can be mounted as close as 1m from the glass.

1. Mounted on opposite wall or Adjoining walls, range is 6m for plate, tempered, laminated and wired glass.
2. Mounted on the ceiling, maximum range is 6m for plate, tempered, laminated and wired glass.
3. For armor-coated glass, mount sensor no more than 3.65m from glass.

**TESTING THE DETECTOR****Proper Testing**

The FW2-GBD is designed to detect the breaking of framed glass mounted in an outside wall. Testing the detector with unframed glass, broken bottles, etc., may not trip the detector.

The FW2-GBD typically does not trip to glass breaking in the middle of the room no burglar breaks glass in the middle of a room, so such breaks are false alarms.

**NOTE:** FW2-GBD may not consistently detect cracks in glass, or bullets that break through the glass. Glass break sensors should always be backed up by interior protection.

**Recommended Glass Size**

Minimum	0.3m x 0.6m or larger
Glass thickness	
Plate:	2.4mm to 6.4mm
Tempered	3.2mm to 6.4mm
Wired	6.4mm
Laminated:	3.2mm to 6.4mm

**USE GLASS BREAK TESTER**

You can use a shock & glass break tester to check the functioning of the detector and the conformity of the installation. (Refer to the manual of your Glass Break tester to select the appropriate mode for testing).

When the Red LED on the detector goes solid momentarily while the tester is triggered, the glass is within detection range.

If the LED does not go solid, but simply continues blinking, re-position the detector closer to the protected windows and retest. This may require adding additional detector(s) in order to achieve adequate coverage.

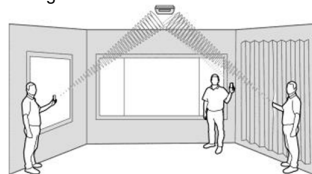
**RSSI – RF SIGNAL INDICATION**

After learning and before installing the detector we recommend to perform walk and transmission tests.

**Tamper Transmission Test**

Changing the tamper switch state (by attaching / removing the device to / from the Base) will cause tamper transmissions.

**Alarm Transmission Test**

During the detector test (using glass break tester), verify RSSI signal level received on your control panel.

**Note:** See control panel installation instruction

**INSTALLATION TIPS**

The FW2-GBD is designed to detect the shattering of framed glass mounted in an outside wall. "Testing" the detector with unframed glass, broken bottles, etc. may not trip the detector. The FW2-GBD typically does not trip to glass break tests in the middle of a room as such breaks are false alarms.

False alarms are most likely to occur when installed on a 24-hour loop in glass airlocks and glass vestibule areas, when mounted above sinks, when used in residential car garages and in other small, acoustically live rooms and rooms where multiple sounds can reflect and eventually duplicate the glass break frequency pattern. For occupied area glass break protection in such applications, use FW2-GBD shock detectors.

Installing the FW2-GBD on 24-hour loops will increase false alarms. The FW2-GBD is recommended for perimeter loops and is designed to function without false alarms in occupied areas. On a 24-hour loop, which is armed all day/all night every day, the false alarm technology will be pushed to its limit since some sounds in some conditions can duplicate the points on the glass break pattern that the FW2-GBD detects.

Install the FW2-GBD on a perimeter loop, which is armed whenever the door and window contacts are armed. For occupied area installations, FW2-GBD false alarm immunity is best in rooms with only moderate noise.

FW2-GBD detects the shattering of glass. Like all Glass Break detectors, it may not consistently detect cracks in glass, or bullets that break through the glass or break out the glass. Glassbreak sensor should always be backed up by interior protection.

**REGULATIONS & STANDARDS****This device complies with:**

EN 300 220-1  
EN 300 220-2  
EN 50130-4  
EN 61000-6-3  
EN 301489-1  
EN 301489-3  
EN 60950-1  
EN 50131-2-7-1  
EN 50131-5-3  
EN 50131-1  
EN 50131-6  
EN 50130-5

Certification Body: Telefication B.V

Security Grade 2, Environmental Class II  
Power Supply Type C

**BATTERY**

The unit is powered by a 3 V Lithium battery.

If the battery reaches a factory preset low level, the "Low Battery" signal will be sent to the control panel and, from this moment, the detector remains operational for another 30 days giving enough time to replace the 3V lithium battery.

**The battery must be replaced by 3V Lithium battery CR123A**

**Models such as**

1. VARTA CR123A
2. GP CR123A

**BATTERY REPLACEMENT**

1. Open the screw cover and separate the detector unit shown in Figure 1.
2. Take out the old battery.
3. Insert new battery as shown in Figure2.
4. Replace the detector unit into the base and close the screw.

**!!! CAUTION !!!**

RISK OF EXPLOSION IF BATTERY IS REPLACED BY AN INCORRECT TYPE.  
DISPOSE OF USED BATTERIES ACCORDING TO THE INSTRUCTIONS.

**TECHNICAL SPECIFICATION**

Detection Method	Omni-directional Shock & Glass Break
Data Protocol	FreeWave2
Modulation Type	GFSK
Frequency	868-869MHz / 916-917MHz
Identification	Unique ID serial number – 24 bit
Events Transmission	Alarm, Tamper, Supervision, Low Bat.
Supervision Time	7 min by default (configurable)
Range in open space	500m
Coverage Area	Up to 6m - 180° radius
Battery	Lithium. 3V Type: CR123A - Size: 2/3AA
Battery life	Up to 4 years
Current	Standby ~11 µA
Consumptions	Receive mode ~24 mA Transmit mode ~45 mA Transmit power ~14dBm
Tamper Switch	Back Tamper (Removal)
Operating temperature	-10°C to +55°C
Dimensions	85mm x 54mm x 24mm
Weight (inc. battery)	120 gr.

**CROW ELECTRONIC ENGINEERING LTD. ("Crow") - WARRANTY POLICY CERTIFICATE**

This Warranty Certificate is given in favor of the purchaser (hereunder the "Purchaser") purchasing the products directly from Crow or from its authorized distributor.

Crow warrants these products to be free from defects in materials and workmanship under normal use and service for a period of 24 months from the last day of the week and year whose numbers are printed on the printed circuit board inside these products (hereunder the "Warranty Period"). Subject to the provisions of this Warranty Certificate, during the Warranty Period, Crow undertakes, at its sole discretion and subject to Crow's procedures, as such procedures are from time to time, to repair or replace, free of charge for materials and/or labor, products proved to be defective in materials or workmanship under normal use and service. Repaired products shall be warranted for the remainder of the original Warranty Period. All transportation costs and in-transit risk of loss or damage related, directly or indirectly, to products returned to Crow for repair or replacement shall be borne solely by the Purchaser.

Crow's warranty under this Warranty Certificate does not cover products that is defective (or shall become defective) due to: (a) alteration of the products (or any part thereof) by anyone other than Crow; (b) accident, abuse, negligence, or improper maintenance; (c) failure caused by a product which Crow did not provide; (d) failure caused by software or hardware which Crow did not provide; (e) use or storage other than in accordance with Crow's specified operating and storage instructions.

There are no warranties, expressed or implied, of merchantability or fitness of the products for a particular purpose or otherwise, which extend beyond the description on the face hereof.

This limited Warranty Certificate is the Purchaser's sole and exclusive remedy against Crow and Crow's sole and exclusive liability toward the Purchaser in connection with the products, including without limitation - for defects or malfunctions of the products. This Warranty Certificate replaces all other warranties and liabilities, whether oral, written, (non-mandatory) statutory, contractual, in tort or otherwise.

In no case shall Crow be liable to anyone for any consequential or incidental damages (inclusive of loss of profit, and whether occasioned by negligence of the Crow or any third party on its behalf) for breach of this or any other warranty, expressed or implied, or upon any other basis of liability whatsoever. Crow does not represent that these products can not be compromised or circumvented; that these products will prevent any person injury or property loss or damage by burglary, robbery, fire or otherwise; or that these products will in all cases provide adequate warning or protection. Purchaser understands that a properly installed and maintained product may in some cases reduce the risk of burglary, fire, robbery or other events occurring without providing an alarm, but it is not insurance or a guarantee that such will not occur or that there will be no personal injury or property loss or damage as a result.

Consequently, Crow shall have no liability for any personal injury, property damage or any other loss based on claim that these products failed to give any warning. If Crow is held liable, whether directly or indirectly, for any loss or damage with regards to these products, regardless of cause or origin, Crow's maximum liability shall not in any case exceed the purchase price of these products, which shall be the complete and exclusive remedy against Crow.



12 Kineret Street.  
Airport City, 70100 Israel  
Tel. +972 39726000  
Fax. +972 39726001  
sales@crow.co.il  
support@crow.co.il  
[www.thecrowgroup.com](http://www.thecrowgroup.com)



These instructions supersede all previous issues in circulation prior to June 2016