



SH-AVM

AUDIO VERIFICATION MODULE



INSTRUCTION MANUAL
P/N XXXXX (D.Z)

PRODUCT FEATURES

The SH-AVM is an indoor audio verification module.

Upon transmission of an alarm signal, the SH-AVM provides remotely controlled and full duplex functionality between a central station operator and the occupants of the premises.

Receiving audio verification simultaneously with the alarm signal allows the CMS to prioritize and verify alarms before acting, making the SH-AVM the ideal solution to false dispatching and unverified alarm problems.

Up to 4 modules can easily be installed in any convenient location in your home.

- DECT Universal Standards
- Push-Button for speed dial emergency call (up to 4 numbers)
- Push-Button for regular call (1 number)
- 500m open space
- 5V supplied from wall mount adaptor
- Built-in rechargeable 3.7V battery for 1 week backup

PRODUCT OVERVIEW

Front View:

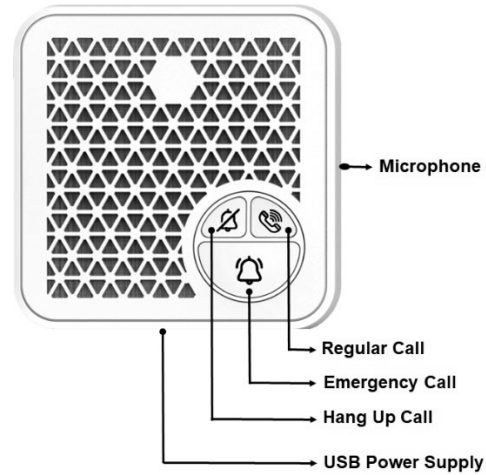

Figure 1

Rear View:

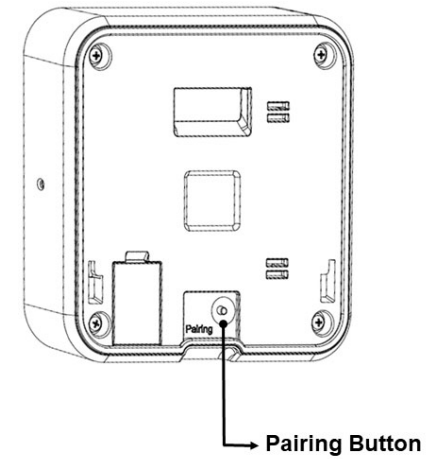

Figure 2

BRACKET REMOVAL

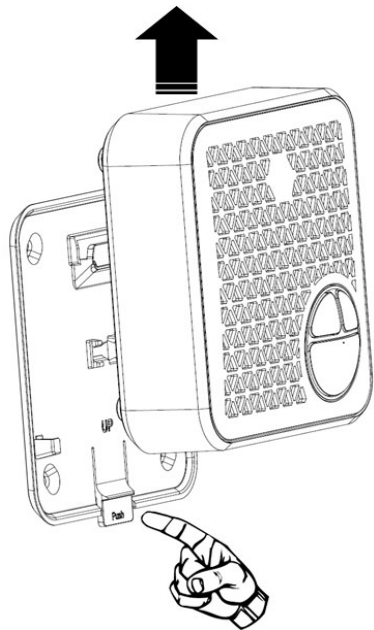

Figure 3

1. Push the latch located on the bracket
2. Slide Up the unit device

WALL MOUNTING

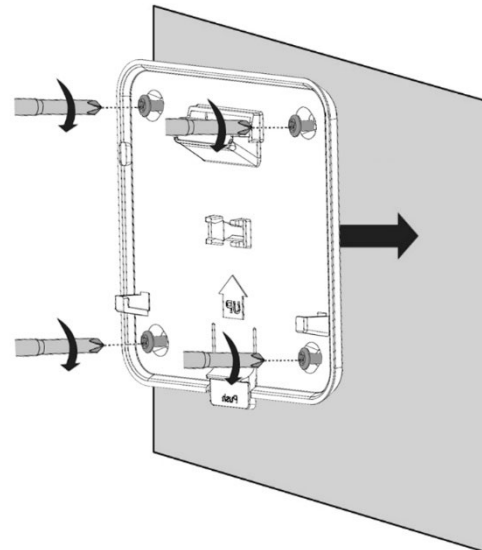

Figure 4

Use supplied screw to mount the bracket on the wall

Check that the base is flat against the wall to facilitate the unit device insertion into the wall bracket.

DEVICE INSTALLATION

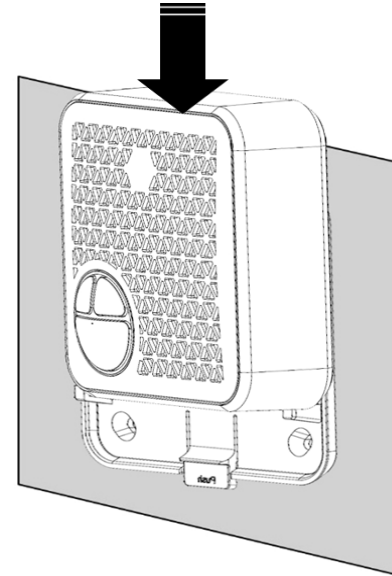

Figure 5

- 1 Slide down the unit device into the bracket
- 2 Plug the USB cable to power the device
- 3 Test the device as indicated in section "Testing the Device"



PAIRING PROCESS

For pairing process, please refer to your control panel instructions.

To pair your Voice module, please proceed as follows:

1. Install the module as indicated on figure 1, 2 and 3.
2. Log into web installer interface and go to "Communication > DECT Learning"
3. Enable the DECT option
4. Press the Pairing button on the back side of the device (figure 2).
5. When the Green LED (Regular Call symbol) starts blinking release the pairing button.
6. Pairing Stage 1 & 2 process is starting. Wait until completion
7. The device should register to the Control Panel.

If registration process failed, the Red LED will blink. Remove the battery, wait for few seconds (~10sec) and repeat the learning process

VOICE MODULE ASSIGNMENT	INCOMING CALLS	SPECIFICATION	STANDARDS APPROVALS																						
<p>After pairing, the voice module must be assigned to your control panel.</p> <p>Go to "Voice Box" and select the desired position from 1 to 20.</p> <p>Click on "Add Voice Box" and Submit the configuration</p>	<p>The Shepherd™ panel gives you the possibility to contact your premises and initiate full duplex calls via the SH-AVM.</p> <p>Up to 4 different phone numbers can be authorized to remotely contact the SH-AVM.</p> <p>Make sure that the Shepherd™ is equipped with SIM card and the GSM option is activated.</p> <ul style="list-style-type: none"> Log into web installer page Go to "Communication" > "Phone Control Remote" Enter up to 4 phone numbers Submit the configuration 	<table border="0"> <tr> <td>Modulation Type</td> <td>DECT Universal Standards</td> </tr> <tr> <td>Event Transmission</td> <td>Emergency Voice Call Low Bat Keep Alive (every 7 minutes – configurable)</td> </tr> <tr> <td>Activation Method</td> <td>Push-Button for speed dial emergency call</td> </tr> <tr> <td>Range</td> <td>500m open space</td> </tr> <tr> <td>Operating voltage</td> <td>5 Volts DC supplied from wall mount adaptor</td> </tr> <tr> <td>Battery</td> <td>Rechargeable Polymer 3.7V 1000mAh</td> </tr> <tr> <td>Current Consumption</td> <td>Talk Mode: 300mA Up to 3 hours talk time in battery mode Standby: 5mA Up to 1 week in battery mode</td> </tr> <tr> <td>LED Indicators</td> <td>Yellow: Hang Up Green: Pair Status OK Speed dial Red: Pairing/HW problem</td> </tr> <tr> <td>Operating Temperature</td> <td>-10°C – +50°C</td> </tr> <tr> <td>Dimensions</td> <td>104mm x 104mm x 29mm</td> </tr> <tr> <td>Weight (incl. battery)</td> <td>150 gr</td> </tr> </table>	Modulation Type	DECT Universal Standards	Event Transmission	Emergency Voice Call Low Bat Keep Alive (every 7 minutes – configurable)	Activation Method	Push-Button for speed dial emergency call	Range	500m open space	Operating voltage	5 Volts DC supplied from wall mount adaptor	Battery	Rechargeable Polymer 3.7V 1000mAh	Current Consumption	Talk Mode: 300mA Up to 3 hours talk time in battery mode Standby: 5mA Up to 1 week in battery mode	LED Indicators	Yellow: Hang Up Green: Pair Status OK Speed dial Red: Pairing/HW problem	Operating Temperature	-10°C – +50°C	Dimensions	104mm x 104mm x 29mm	Weight (incl. battery)	150 gr	<p>The SH-AVM conforms to the essential requirements set out by:</p> <ul style="list-style-type: none"> RED directive: 2014/53/EU EMC directive: 2014/30/EU Low Voltage directive: 2014/35/EU <p>Harmonized Standards applicable to this products are:</p> <ul style="list-style-type: none"> EN300220-2 EN300220-1 EN301489-3 EN301489-1 EN50130-4 EN61000-6-3 EN60950-1 EN50131-6 EN50130-5 EN50131-5-3 <p>Security Grade 2 Environmental Class II</p> <p>Additional Standards and Directives applicable to this product are:</p> <ul style="list-style-type: none"> RoHS directive: 2002/95/EC EN50131-4 <p>Security Grade2, Environmental Class II Power supply Type C</p>  
Modulation Type	DECT Universal Standards																								
Event Transmission	Emergency Voice Call Low Bat Keep Alive (every 7 minutes – configurable)																								
Activation Method	Push-Button for speed dial emergency call																								
Range	500m open space																								
Operating voltage	5 Volts DC supplied from wall mount adaptor																								
Battery	Rechargeable Polymer 3.7V 1000mAh																								
Current Consumption	Talk Mode: 300mA Up to 3 hours talk time in battery mode Standby: 5mA Up to 1 week in battery mode																								
LED Indicators	Yellow: Hang Up Green: Pair Status OK Speed dial Red: Pairing/HW problem																								
Operating Temperature	-10°C – +50°C																								
Dimensions	104mm x 104mm x 29mm																								
Weight (incl. battery)	150 gr																								
EMERGENCY CALL SET UP	<p>The Shepherd™ panel can broadcast pre-programmed messages into your premises via the SH-AVM.</p> <p>These pre-programmed messages can be also reported by phone calls to up to 4 recipients.</p> <ul style="list-style-type: none"> Log into web installer page Go to "Report Channel" Select Voice channel type Enter recipient phone number Submit the configuration <p>Note: To receive pre-programmed message by phone, make sure that the Shepherd™ is equipped with SIM card and the GSM option is activated.</p>																								
<p>The SH-AVM can make emergency phone calls to up 4 different phone numbers.</p> <p>Make sure that the Shepherd™ is equipped with SIM card and the GSM option is activated.</p> <ul style="list-style-type: none"> Log into web installer page Go to "Communication" > DECT section Enter up to 4 phone numbers Submit the configuration <p>Note: On incoming call, the recipient must press the Hash "#" button within 30 seconds to acknowledge the call reception and stop the rolling dialing process.</p>				MESSAGES BROADCASTING																					
REGULAR CALL SET UP																									
<p>The SH-AVM can make regular phone call to 1 phone number only.</p> <p>Make sure that the Shepherd™ is equipped with SIM card and the GSM option is activated.</p> <ul style="list-style-type: none"> Log into web installer page Go to "USER" and select the user who will receive the call Fill phone number and Submit the configuration 																									
WARRANTY POLICY CERTIFICATE																									
<p>Crow warrants these products to be free from defects in materials and workmanship under normal use and service for a period of 24 months from the last day of the week and year whose numbers are printed on the printed circuit board inside these products.</p> <p>Subject to the provisions of this Warranty Certificate, during the Warranty Period, Crow undertakes, at its sole discretion and subject to Crow's procedures, as such procedures are from time to time, to repair or replace, free of charge for materials and/or labor, products proved to be defective in materials or workmanship under normal use and service. Repaired products shall be warranted for the remainder of the original Warranty Period.</p> <p>All transportation costs and in-transit risk of loss or damage related, directly or indirectly, to products returned to Crow for repair or replacement shall be borne solely by the Purchaser.</p> <p>This Warranty Certificate does not cover products that is defective (or shall become defective) due to: (a) alteration of the products (or any part thereof) by anyone other than Crow; (b) accident, abuse, negligence, or improper maintenance; (c) failure caused by a product which Crow did not provide; (d) failure caused by software or hardware which Crow did not provide; (e) use or storage other than in accordance with Crow's specified operating and storage instructions.</p> <p>There are no warranties, expressed or implied, of merchantability or fitness of the products for a particular purpose or otherwise, which extend beyond the description on the face hereof.</p> <p>This limited Warranty Certificate is the Purchaser's sole and exclusive remedy against Crow and Crow's sole and exclusive liability toward the Purchaser in connection with the products, including without limitation - for defects or malfunctions of the products. This Warranty Certificate replaces all other warranties and liabilities, whether oral, written, (non-mandatory) statutory, contractual, in tort or otherwise.</p> <p>In no case shall Crow be liable to anyone for any consequential or incidental damages (inclusive of loss of profit, and whether occasioned by negligence of the Crow or any third party on its behalf) for breach of this or any other warranty, expressed or implied, or upon any other basis of liability whatsoever.</p> <p>Crow does not represent that these products can not be compromised or circumvented; that these products will prevent any person injury or property loss or damage by burglary, robbery, fire or otherwise; or that these products will in all cases provide adequate warning or protection.</p> <p>Purchaser understands that a properly installed and maintained product may in some cases reduce the risk of burglary, fire, robbery or other events occurring without providing an alarm, but it is not insurance or a guarantee that such will not occur or that there will be no personal injury or property loss or damage as a result. Consequently, Crow shall have no liability for any personal injury; property damage or any other loss based on claim that these products failed to give any warning. If Crow is held liable, whether directly or indirectly, for any loss or damage with regards to these products, regardless of cause or origin, Crow's maximum liability shall not in any case exceed the purchase price of these products, which shall be the complete and exclusive remedy against Crow.</p>		 <p>sales@crow.co.il support@crow.co.il</p> <p>www.thecrowgroup.com</p> <p>These instructions supersede all previous issues in circulation prior to April 2019</p>																							