



**SH-KP-ADV-8F /9F**  
TWO WAY WIRELES ADVANCED ICON KEYPAD  
WITH RFID READER FOR SHEPHERD™ PANELS



INSTRUCTION MANUAL  
P/N 7102382\_A

**KEYPAD DESCRIPTION**

The SH-KP is a 2 way wireless Icon keypad with a built-in RFID reader designed to work with the Shepherd™ panel.

- Easy and user-friendly control
- Back Light indication
- Integrated panic and alerts functions
- Keypad loudness control
- Up to 3 years battery life
- Events transmission:
  - Arm / Disarm
  - Panic and Alerts: Fire and Medical
  - Tamper Open/Close
  - Supervision
  - Battery status
- Up to 4 keypads per Shepherd™ panel
- Getting Panel Status ARM/STAY ARM
- Outputs can be operated
- Pin Code User: 4,6,8 digits
- Siren & KP buzzer timeout control ( on panic event only)
- Panic Alarm visibility control (KP Leds)
- Audible Panic Alarm control (KP buzzer sound)
- Button loudness control (KP keys sound)
- Fast ARM/STAY ARM function
- Remotely configurable
- Wall mounted or can be used as portable unit
- Acoustic alarm by sounder

**OVERVIEW**

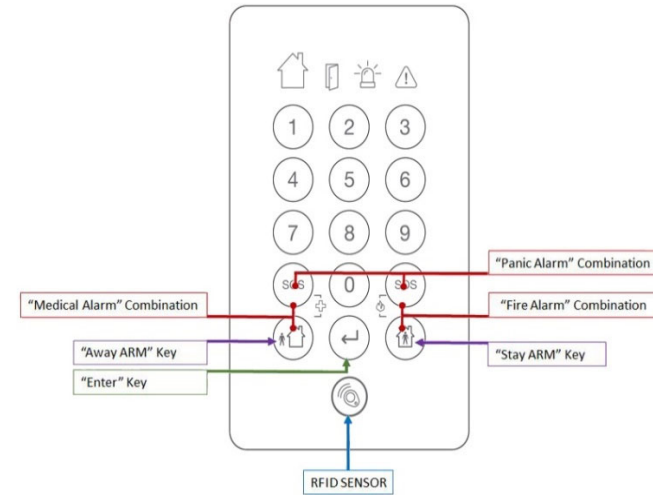

Figure 1

**KEYPAD OPENING**

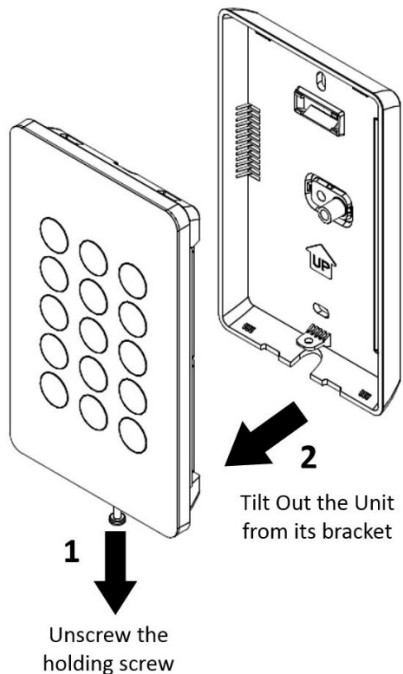

Figure 2

**WALL MOUNTING**

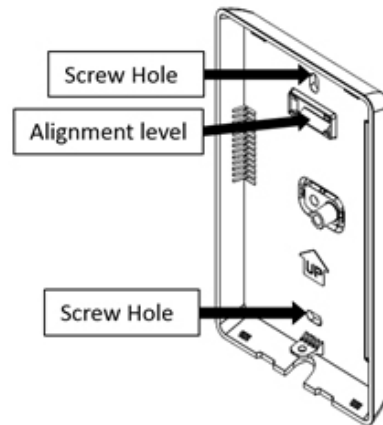



Figure 3  
Wall bracket installation

1. Place the bracket on the wall. Check that the base is flat against the wall to facilitate the unit device insertion into the wall bracket
2. Use the built-in alignment level to verify the correct position.
3. Draw 2 holes on the wall and drill into the wall
4. Use supplied screws to mount the bracket on the wall.

**PAIRING PROCESS**

1. Log into Installer webpage : <https://installer.crowcloud.xyz>
2. Select the panel you want to configure and go to "Keypads" level.
3. Click on the keypad position you want to add.
4. Add Keypad, Set the link type "ISM" , insert device's ID serial number, device type : select Advanced Keypad, configure the required parameters and save configuration.
5. Insert batteries into keypad as per Figure 4.
6. The Keypad will start its power up process:

The Green Led indication  will switch ON for 3 seconds and then Red and Green Leds blinking alternately during device initialization until the device is ready for use.

7. When registration process is completed, the Green LED will freeze for 3 seconds and then turn OFF.

**KEYPAD Configuration**

Fast arm	Enabled	Enable or disable of Fast
Key ARM action		
Fast stay arm	Enabled	Enable or disable of Fast
Key STAY ARM action		
Pin code size	4 digits	Select user pin code size
Siren Timeout	30 seconds	Timeout of Siren and KP buzzer can be set by this time (relevant on panic event only).
panic alarm visibility	Enabled	Enable or disable of red light indication  during panic event.
Audible panic alarm	Enabled	Enable or disable of KP buzzer sound.
Button loudness	Full	Keypad keys sound level.
Siren loudness	Full	KP buzzer sound control level.

**BATTERIES INSERTION**

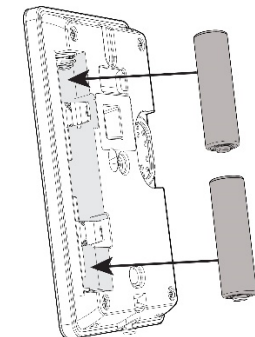

Figure 4

Batteries can be replaced by user  
Place batteries according to their polarity.

**CAUTION**

**RISK OF EXPLOSION**  
IF BATTERIES ARE REPLACED BY DIFFERENT TYPES / MODELS.  
DISPOSE USED BATTERIES ACCORDING TO INSTRUCTIONS

**BATTERIES MUST BE REPLACED BY 2 Energizer L91 BATTERIES AA 1.5V LITHIUM**

**RFID TAG LEARNING**

**KEYPAD OPERATIONS**

**KEYPAD OPERATIONS**

**SPECIFICATION**

For Learning process, please refer to your control panel instructions.

1. Log into Installer webpage : <https://installer.crowcloud.xyz>
2. Go to USER in programming mode , select user number , go to tag section and click the button

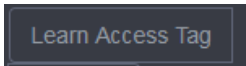

3. The learning process will start
4. Approach the tag to the RFID symbol on the keypad



5. Beep sounds and RFID led flashes
6. Confirm OK and Submit new configuration to the panel.

**SYSTEM AWAY ARM**

Key + Enter User Code

---

OR

Press on AWAY key + approach Tag to

**SYSTEM HOME ARM**

Key + Enter User Code

**SYSTEM DISARM**

Enter User Code

---

OR

Approach Tag to

**SYSTEM PANIC**

Press both buttons simultaneously

**FIRE ALERT**

Press both + buttons simultaneously

**MEDICAL ALERT**

Press both + buttons simultaneously

**OUTPUT ACTIVATION**

Press on Required output No. + Followed by Enter Key

**GETTING PANEL STATUS ARM / STAY ARM**

Press on any Key + ARM / STAY ARM Red light is on accordingly

**FAST ARM / STAY ARM ACTION**

Press the Key and Hold for 4 sec. Press the Key and Hold for 4 sec.

**NOTE :** Minimum acoustic output level from 1 meter - more than 80db(A)

Operation Method	Icon Keypad & RFID & Siren
Communication Protocol	Freewave2™ Two Way ISM GFSK with 5 frequencies & LBT
Frequency Band	868-869MHz or 916-917MHZ
Identification	Unique ID serial number – 24 bit
RFID	ISO 15693
Functions	Arm, Disarm, Zone Bypass, Panic Alerts, Local Program mode (users/tags), acoustic alarm
Communication Range	500 m in open space
Current Consumptions	Standby: 4µA Average: 10mA Transmission ~28 mA Transmit power up to 14 dBm
Batteries	2 x Energizer L91 Lithium batteries Type AA Low.Batt. 2.3V
Battery Life	Up to 3 years
Operating Temperature	-10°C to +55°C
Dimensions	143mm x 85mm x 20mm
Weight (Inc. bat)	200 gr
Type of power supply	W for siren C for keypad



## WARRANTY POLICY CERTIFICATE

Crow warrants these products to be free from defects in materials and workmanship under normal use and service for a period of 24 months from the last day of the week and year whose numbers are printed on the printed circuit board inside these products.

Subject to the provisions of this Warranty Certificate, during the Warranty Period, Crow undertakes, at its sole discretion and subject to Crow's procedures, as such procedures are from time to time, to repair or replace, free of charge for materials and/or labor, products proved to be defective in materials or workmanship under normal use and service. Repaired products shall be warranted for the remainder of the original Warranty Period. All transportation costs and in-transit risk of loss or damage related, directly or indirectly, to products returned to Crow for repair or replacement shall be borne solely by the Purchaser.

This Warranty Certificate does not cover products that is defective (or shall become defective) due to: (a) alteration of the products (or any part thereof) by anyone other than Crow; (b) accident, abuse, negligence, or improper maintenance; (c) failure caused by a product which Crow did not provide; (d) failure caused by software or hardware which Crow did not provide; (e) use or storage other than in accordance with Crow's specified operating and storage instructions.

There are no warranties, expressed or implied, of merchantability or fitness of the products for a particular purpose or otherwise, which extend beyond the description on the face hereof. This limited Warranty Certificate is the Purchaser's sole and exclusive remedy against Crow and Crow's sole and exclusive liability toward the Purchaser in connection with the products, including without limitation - for defects or malfunctions of the products.

This Warranty Certificate replaces all other warranties and liabilities, whether oral, written, (non-mandatory) statutory, contractual, in tort or otherwise. In no case shall Crow be liable to anyone for any consequential or incidental damages (inclusive of loss of profit, and whether occasioned by negligence of the Crow or any third party on its behalf) for breach of this or any other warranty, expressed or implied, or upon any other basis of liability whatsoever. Crow does not represent that these products can not be compromised or circumvented; that these products will prevent any person injury or property loss or damage by burglary, robbery, fire or otherwise; or that these products will in all cases provide adequate warning or protection. Purchaser understands that a properly installed and maintained product may in some cases reduce the risk of burglary, fire, robbery or other events occurring without providing an alarm, but it is not insurance or a guarantee that such will not occur or that there will be no personal injury or property loss or damage as a result.

Consequently, Crow shall have no liability for any personal injury; property damage or any other loss based on claim that these products failed to give any warning. If Crow is held liable, whether directly or indirectly, for any loss or damage with regards to these products, regardless of cause or origin, Crow's maximum liability shall not in any case exceed the purchase price of these products, which shall be the complete and exclusive remedy against Crow.



[info@crow.co.il](mailto:info@crow.co.il)  
[support@crow.co.il](mailto:support@crow.co.il)

[www.thecrowgroup.com](http://www.thecrowgroup.com)

**These instructions supersede all previous issues**

## Compliance

The SH-KP conforms to the essential requirements set out by:

- EMC directive: 2014/30/EU
- LVD directive: 2014/35/EU
- RE directive (RED): 2014/53/EU
- RoHS3 directive: 2015/863/EU

Harmonized Standards applicable to this products are:

- EN 50130-4
- EN 61000-6-3
- EN 301 489-1
- EN 301 489-3
- EN 300 220-1
- EN 300 220-2
- EN 300 330
- EN 62368-1

Additional Standards and Directives applicable to this product are:

- EN 50131-1
- EN 50131-3
- EN 50131-6
- EN 50131-5-3
- EN 50130-5
- EN 50131-4

Certification body: Tefelocation B.V.  
Security Grade2, Environmental Class II