

DECT ULE - MAG NC

MAGNETIC CONTACT

CR-DU-MAG NC EURO
CR-DU-MAG NC USA



ELECTRONIC ENGINEERING LTD.

INSTALLATION INSTRUCTIONS

P/N 7101342 REV. B (O.Z.)

Issue Date: November 29th, 2016

INTRODUCTION

This DECT ULE MAG NC detector is an advanced, fully supervised low-current wireless detector that includes a DECT ULE transceiver for reliable system operation.

This DECT ULE MAG NC uses smart message control, which verifies that all messages are successfully transmitted, so that no intrusion event will be uninformed to the system.

This DECT ULE MAG NC detector includes series of messages for full communication administration (Keep Alive, Tamper Status, Battery Status, Alert, Configuration, etc.) as well as test transmission signals.

FEATURES

- DECT ULE RF protocol.
- Low current Technology.
- Powered by two 1.5V Lithium batteries type AAA.
- Battery life: up to 4 years.
- Frequency Band: All DECT Standard Bands.
- Contact Open/Close transmission.
- Tamper Open/Close transmission.
- Keep Alive transmission.
- Battery status transmission.
- Bi-Color LED indications for Monitoring & Pairing.
- Range up to 500m on open space.
- Alarm trigger by 2 internal magnetic sensors.
- Remotely configurable.
- Friendly Pairing and Installation processes.

OPERATION

The DECT ULE MAG NC detector transmits the following events data:

KEEP ALIVE – A periodical transmission indicating detector's presence. The time interval is configurable – the minimum value is 3 seconds.

ALARM – Alarm transmission triggered by the device indicating intrusion detection. The Red LED will blink once.

LOW BAT – Whenever the battery reaches a pre-set low level (~2.5V) Battery Low signal will be sent. When Battery level drops below Cut Off level (~2.3V) the device will stop functioning and the Red LED will blink for 10 seconds.

TAMPER – Whenever the cover is removed from Bracket, a message will be transmitted with "Tamper ON" signal. When cover will be returned a "Tamper OFF" signal will be transmitted.

BATTERY REPLACEMENT

1. Use a screw driver to press the small hole and pull the cover up as shown in Figure 1.
2. Remove the cover completely and reveal the Battery compartment as shown in Figure 2.
3. Remove the in used battery from the device.
4. Place two 1.5V Lithium batteries type AAA in the correct polarity marking as marked on the Plastic and as instructed in Figure 2.
5. Wait until the Red LED stops blinking.
6. In case the device was paired to a Base Station the device should automatically register again to the same Base Station and the Green LED shall constantly light On for 3 seconds.
7. In case the device is **NOT** pair to a Base Station continue with the Pairing process as explained below.
8. Place the cover back into its appropriate position and press it towards the bracket until it is nicely closed in all the directions. Validate receiving the Tamper Alert Off indication on your Application / Base Station.

FIGURE 1 – SEPARATE FROM BRACKET

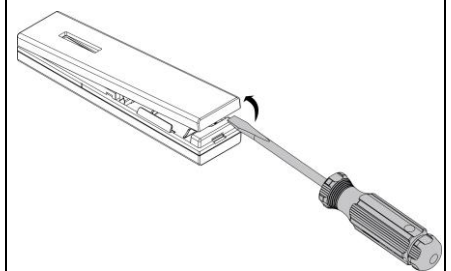
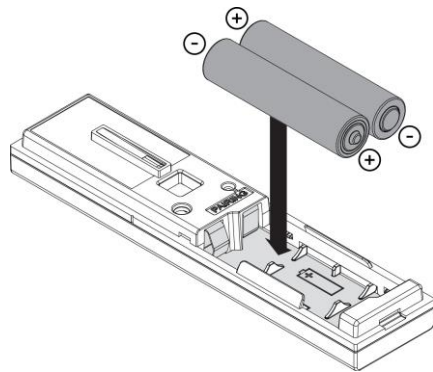

FIGURE 2 – BATTERY PLACEMENT



PAIRING PROCESS

1. Open the device as describe in the "Battery Replacement" above steps 1-2.
2. Verify that the two 1.5V Lithium batteries are placed in the correct polarity as instructed in Figure 2.
3. Initiate the Base Station pairing process.
4. Initiate the device pairing process by pressing the pairing button for 5 seconds – the pairing button is shown in Figure 3. The Green LED will constantly turn On. When the Green LED starts blinking release the pairing button.
5. The device should register to the Base Station.
6. When registration process is successfully completed the Green LED will constantly light On for 3 seconds and then turn off.
7. If registration process failed the Red LED will blink (remove the battery and run the pairing process again).

FIGURE 3 – PAIRING

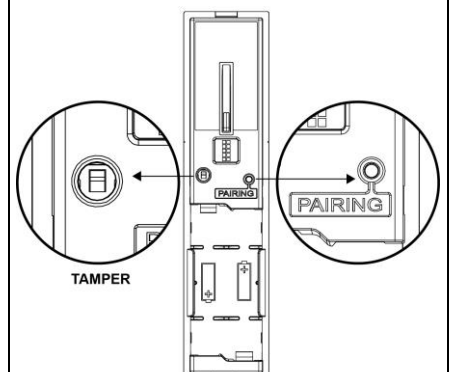

SELECT MOUNTING LOCATION

As the device is a wireless transceiver, and in order to take full advantage of it's sophisticated operation, do not install the detector in areas where large metal objects could interfere with the transmission of signals. Installation is not allowed on a ferromagnetic surface.

TRANSMISSION TESTS

Tamper transmission test –

Changing the tamper switch state (by attaching / removing the cover to / from its bracket) will cause tamper transmissions.

Open/Close transmission test –

Removing / Placing the small magnet from / to the device will cause Open / Close alert transmission.

Identification transmission test –

Use your Application / Base Station and send Identification Request to the device. The device will start blinking the Green & Red LEDs alternately – 5 times each LED starting with the Green LED.

WAY OF INSTALLATION

It is recommended to mount the device vertically on a flat area to get maximum range.

It is recommended to attach the detector to the fixed frame and the small magnet to the moveable part (door or window), as shown on Figure 4. It is very important to mount the small magnet part as closes as possible to the transmitter part and in the correct location.

The small magnet can be installed on both detectors' sides.

IMPORTANT!!!

On the detectors' both sides there is a small socket which marks the center of the small magnet location – see Figure 6. Make sure that the center of the small magnet will be installed against one of these marks – see Figure 5.

The height of the small magnet relatively to the detector part should be no more than 10mm lower or higher or to the side of the detector. Figures 5 illustrate one option of installation.

FIGURE 4 – WAY OF INSTALLATION

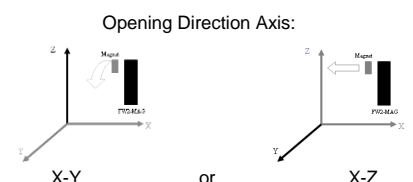
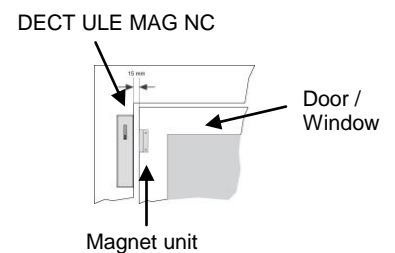
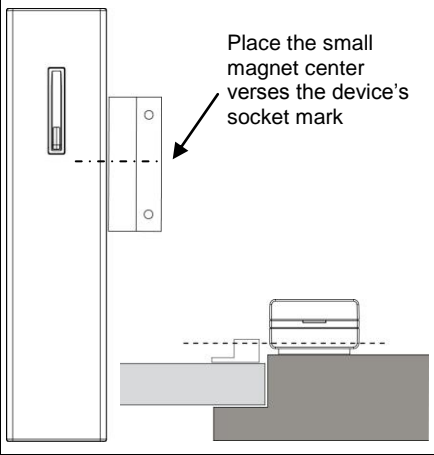

FIGURE 5 – MOUNTING THE DEVICE**FCC & IC STATEMENT****FCC ID: NFC-CRDU****IC: 8164A-CRDU**

This device complies with FCC Rules Part 15 and with Industry Canada license-exempt RSS standard(s). Operation is subject to two conditions: (1) this device may not cause harmful interference, and (2) this device must accept any interference that may be received or that may cause undesired operation.

This equipment complies with FCC radiation exposure limits set forth for an uncontrolled environment. End users must follow the specific operating instructions for satisfying RF exposure compliance. This transmitter must not be co-located or operating in conjunction with any other antenna or transmitter.

Canada: Under Industry Canada regulations, this radio transmitter may only operate using an antenna of a type and maximum (or lesser) gain approved for the transmitter by Industry Canada. To reduce potential radio interference to other users, the antenna type and its gain should be so chosen that the equivalent isotropically radiated power (e.i.r.p.) is not more than that necessary for successful communication. This device complies with Industry Canada licence-exempt RSS standard(s).

REGULATORY APPROVALS

This DECT ULE MAG NC detector conforms to the essential requirements set out by:

- RTTE directive: 1999/5/EC
- EMC directive: 2004/108/EC
- Low Voltage directive: 2006/95/EC
- RoHS directive: 2011/65/EU

Harmonized Standards applicable to this products are:

- EN301406
- EN301489-6
- EN301489-1
- EN61000-6-3
- EN60950-1
- EN50581
- UL 634
- ULC/ORD-C634-86

**CROW ELECTRONIC ENGINEERING LTD. ("Crow") - WARRANTY POLICY CERTIFICATE**

This Warranty Certificate is given in favor of the purchaser (hereunder the "Purchaser") purchasing the products directly from Crow or from its authorized distributor.

Crow warrants these products to be free from defects in materials and workmanship under normal use and service for a period of 24 months from the last day of the week and year whose numbers are printed on the printed circuit board inside these products (hereunder the "Warranty Period").

Subject to the provisions of this Warranty Certificate, during the Warranty Period, Crow undertakes, at its sole discretion and subject to Crow's procedures, as such procedures are from time to time, to repair or replace, free of charge for materials and/or labor, products proved to be defective in materials or workmanship under normal use and service. Repaired products shall be warranted for the remainder of the original Warranty Period. All transportation costs and in-transit risk of loss or damage related, directly or indirectly, to products returned to Crow for repair or replacement shall be borne solely by the Purchaser.

Crow's warranty under this Warranty Certificate does not cover products that is defective (or shall become defective) due to: (a) alteration of the products (or any part thereof) by anyone other than Crow; (b) accident, abuse, negligence, or improper maintenance; (c) failure caused by a product which Crow did not provide; (d) failure caused by software or hardware which Crow did not provide; (e) use or storage other than in accordance with Crow's specified operating and storage instructions.

There are no warranties, expressed or implied, of merchantability or fitness of the products for a particular purpose or otherwise, which extend beyond the description on the face hereof.

This limited Warranty Certificate is the Purchaser's sole and exclusive remedy against Crow and Crow's sole and exclusive liability toward the Purchaser in connection with the products, including without limitation - for defects or malfunctions of the products. This Warranty Certificate replaces all other warranties and liabilities, whether oral, written, (non-mandatory) statutory, contractual, in tort or otherwise.

In no case shall Crow be liable to anyone for any consequential or incidental damages (inclusive of loss of profit, and whether occasioned by negligence of the Crow or any third party on its behalf) for breach of this or any other warranty, expressed or implied, or upon any other basis of liability whatsoever. Crow does not represent that these products can not be compromised or circumvented; that these products will prevent any person injury or property loss or damage by burglary, robbery, fire or otherwise; or that these products will in all cases provide adequate warning or protection.

Purchaser understands that a properly installed and maintained product may in some cases reduce the risk of burglary, fire, robbery or other events occurring without providing an alarm, but it is not insurance or a guarantee that such will not occur or that there will be no personal injury or property loss or damage as a result.

Consequently, Crow shall have no liability for any personal injury; property damage or any other loss based on claim that these products failed to give any warning.

If Crow is held liable, whether directly or indirectly, for any loss or damage with regards to these products, regardless of cause or origin, Crow's maximum liability shall not in any case exceed the purchase price of these products, which shall be the complete and exclusive remedy against Crow.

MOUNTING THE DEVICE

1. Installed the batteries as explained above
2. Pair the device as explained above.
3. Mount the device to the surface using the adhesive tape strip as shown in Figure 6.
4. Before mounting the small Magnet part mark the correct location on the moveable part and validate the installation location by generating Open / Close Alert indication.
5. Mount the small Magnet part on the moveable part in the correct location as marked, using the adhesive tape or the supplied screws as shown in Figures 4 & 5.

FCC & IC STATEMENT (Continue)

Operation is subject to the following two conditions: (1) this device may not cause interference, and (2) this device must accept any interference, including interference that may cause undesired operation of the device.

Conformément à la réglementation d'Industrie Canada, le présent émetteur radio peut fonctionner avec une antenne d'un type et d'un gain maximal (ou inférieur) approuvé pour l'émetteur par Industrie Canada. Dans le but de réduire les risques de brouillage radioélectrique à l'intention des autres utilisateurs, il faut choisir le type d'antenne et son gain de sorte que la puissance isotrope rayonnée équivalente (p.i.r.e.) ne dépasse pas l'intensité nécessaire à l'établissement d'une communication satisfaisante. Le présent appareil est conforme aux CNR d'Industrie Canada applicables aux appareils radio exempts de licence. L'exploitation est autorisée aux deux conditions suivantes : (1) l'appareil ne doit pas produire de brouillage, et (2) l'utilisateur de l'appareil doit accepter tout brouillage radioélectrique subi, même si le brouillage est susceptible d'en compromettre le fonctionnement.

TECHNICAL SPECIFICATIONS

RF Protocol	DECT ULE Standard
Modulation Type	GFSK
Frequency	1880–1900 MHz - Europe 1920–1930 MHz - USA/Canada
Event Transmission	Alarm, Tamper, Keep Alive, Battery status.
Detection Method	2 internal magnetic sensors .
Range in open space	>500m
Batteries	Two 1.5V Lithium batteries type AAA
Battery life	>5 years (10 activation per day)
Current Consumptions:	
Standby	8µA
Average	23µA
Maximum (TX)	250mA
Low Battery	2.5VDC
Cut Off Battery	2.3VDC
Transmit Power (Typ.):	23dBm (EURO), 20dBm (USA)
Tamper Switch	Tamper
Operating temperature	-10°C to +55°C
Dimensions	190mm x 25mm x 14mm
Weight	250 gr.
Weight (inc. batteries)	400 gr.

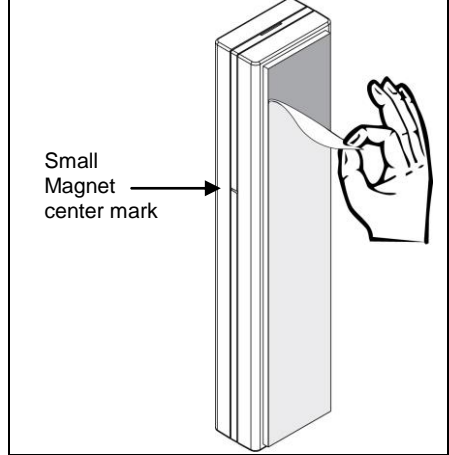
FIGURE 6 – MOUNTING THE DEVICE**FCC & IC STATEMENT (Continue)**

Note: The digital circuit of this device has been tested and found to comply with the limits for a Class B digital device, pursuant to part 15 of the FCC Rules. These limits are designed to provide reasonable protection against harmful interference in a residential installation. This equipment generates uses and can radiate radio frequency energy and, if not installed and used in accordance with the instructions, may cause harmful interference to radio communications. However, there is no guarantee that interference will not occur in a particular installation. If this equipment does cause harmful interference to radio or television reception, which can be determined by turning the equipment off and on, the user is encouraged to try to correct the interference by one or more of the following measures: -Reorient or relocate the receiving antenna. -Increase the separation between the equipment and receiver. -Connect the equipment into an outlet on a circuit different from that to which the receiver is connected. -Consult the dealer or an experienced radio/TV technician for help.

CAUTION !!!

RISK OF EXPLOSION IF BATTERIES ARE REPLACED BY DIFFERENT TYPE / MODEL. DISPOSE USED BATTERIES ACCORDING TO ITS INSTRUCTIONS

ATTENTION !!!

RISQUE D'EXPLOSION SI LA PILE EST REMPLACÉE PAR UN TYPE INCORRECT.

WARNING!!!

CHANGES OR MODIFICATIONS TO THIS EQUIPMENT NOT EXPRESSLY APPROVED BY THE PARTY RESPONSIBLE FOR COMPLIANCE (CROW ELECTRONIC ENGINEERING LTD.) COULD VOID THE USER'S AUTHORITY TO OPERATE THE EQUIPMENT.

CROW ELECTRONIC ENGINEERING LTD.

12 Kineret St.
Airport City, 70100 Israel
Tel. +972 3 9726000
Fax. +972 3 9726001
sales@crow.co.il
support@crow.co.il
www.thecrowgroup.com

CROW LATIN AMERICA USA INC.

7200 NW 19 st.
Suite 307
Miami FI 33126, USA
Tel. +305 513 4001
Fax. +305 513 4005
rejana@crowlatinamerica.com
www.crowlatinamerica.com